

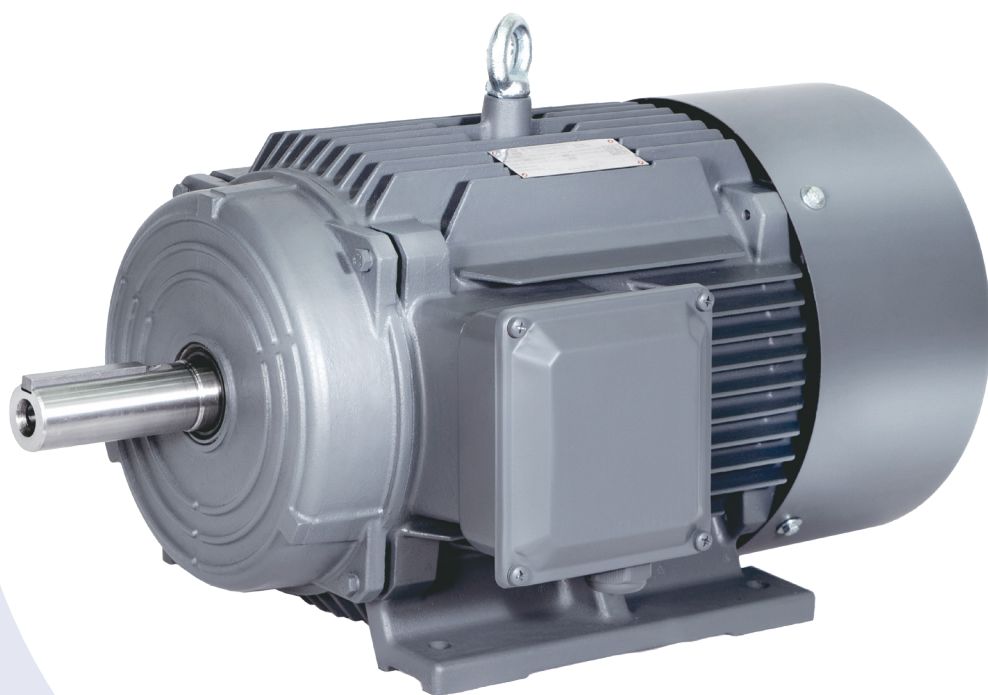

1TL0004 铸铁系列高效低压三相异步电动机
1TL0004 Cast Iron series Low-voltage
Three-phase Asynchronous Motor

产品样本 Catalog
2022.10



公司概况 Company Profile



西门子电机（中国）有限公司 Siemens Standard Motors Ltd. (SSML)

西门子电机（中国）有限公司是西门子在中国的独资企业，位于江苏省仪征市，公司主要致力于研发和生产中小型低压三相异步电动机。目前生产符合 IEC 标准的西门子品牌三相异步电动机、以及按中国标准设计的贝得品牌系列三相异步电动机。

作为西门子在全球中小型低压电机产品的重要生产基地之一，公司坚持秉承西门子 100 多年的电动机设计和生产经验和先进技术，拥有先进的生产设备和生产工艺，采用西门子特色的现代化管理模式，严格按照国际标准 ISO9001:2015 实施全面质量管理，竭诚为广大客户提供优质的产品和服务！

Siemens Standard Motors Ltd. (SSML) is a Siemens-owned company in China. SSML is located in Yizheng City, Jiangsu Province. The company focuses on developing and producing small and medium low-voltage motors. Currently, SSML mainly produce Siemens brand low voltage AC motors according to IEC standards, and Beide brand low voltage motors designed according to China local standards.

As one of Siemens main low-voltage motor production facilities worldwide, SSML uses the knowledge and experience of more than 100 years in motor design and manufacturing, owns the advanced manufacture equipment and process, adopts the SIEMENS modern management model, and implements comprehensive quality control according to ISO9001 2015. SSML will continuously serve customers with high quality products and good service.

公司概况 Company Profile



质量方针

- 质量从我做起，第一次把事情做对。
- 鼓励员工发现问题并勇于承担责任。
- 拒不接受不合格产品。
- 持续改进我们的流程，超越客户期望。

环境方针

西门子电机（中国）有限公司的环境、职业健康和安全管理方针是：

- 我们依据 ISO14001:2015 和 ISO 45001-2018 标准的要求，有效建立、实施环境和职业健康安全管理体系，不断提高，持续改进。
- 我们承诺遵守环境、职业健康安全相关的法律法规，履行环境保护及职业健康安全防护职责。
- 我们致力于履行应负的社会责任和义务，合理使用资源，保护环境，加强职业健康安全管理，实现安全生产零伤害。

Quality Guideline

- Quality starts with me, Do it right in the first time.
- Encourage our employee to address problem openly and take responsibility.
- Refuse to accept defective product.
- Continuously improve our process to exceed customer's expectation.

Environmental Guideline

EHS Policy of Siemens Standard Motors Ltd. is as follows:

- We institute and implement a continuously improving management system addressing our environment, occupational health and safety in compliance with the requirements of ISO14001:2015 and ISO 45001-2018 criteria.
- We commit ourselves to abiding by the environmental, occupational health and safety laws and regulations, and fulfilling our duties in environmental protecting and occupational health safeguarding.
- We commit ourselves to the fulfillment of our social responsibility and obligation, properly harnessing resources, protecting our environment, enhancing occupational health and safety management with the ultimate goal of zero harm in our production process.

目录 Contents

概述 Overview	5
变频应用 Converter fed application	11
订货号 Order No.	13
选型技术数据表 Technical data table	15
选件 Options	18
外形尺寸 Dimension drawings	20

概述 Overview

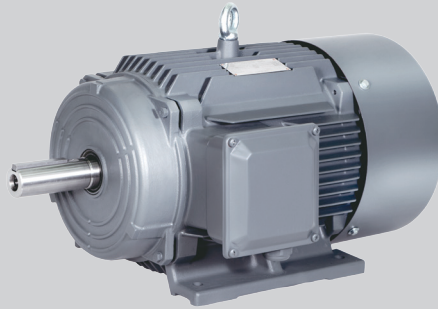

铸铁壳电机 Cast iron housing motor

额定功率：1.5 ~ 315 kW

机座号：100 ~ 355

电压与频率：支持多种电压与频率

冷却方式：IC411

注油装置：机座号 180 ~ 355 的电机标配

防护等级：IP55

绝缘等级：F

环境温度：-15 ~ 40 °C

海拔高度：不超过 1000 m

Rated output: 1.5 ~ 315 kW

Frame size: 100 ~ 355

Voltage and Frequency: support multiple voltage and frequency

Cooling method: IC411

Oiling device: FS180~355 motor as standard

Degree of protection: IP55

Degree of insulation: F

Coolant temperature: -15 ~ 40 °C

Site altitude above sea level: not exceed 1000 m

1TL0004 系列电动机是全新设计的高效低压三相异步电动机，适用于连续工作制（S1）工作运行。1TL0004 系列电动机具有效率高、结构新颖、造型美观、噪音低、振动小、绝缘等级高等特点，可用于风机、泵、压缩机、纺织机械等多种工业应用领域。

1TL0004 series of motors is the newly designed high efficiency low voltage three phase asynchronous motor, is designed for continuous duty operation(S1). 1TL0004 series of motors owns the features of high efficiency, novel structure, beautiful appearance, low noise, small vibration, high degree of insulation, etc, also can be used in the fields of fans, pump, compressors and textile machine.

参考标准 Reference standards

名称 Title	IEC 标准 IEC standard	中国国家标准 Chinese standard
旋转电动机定额和性能 Rotating electrical machines – Part 1: Rating and performance	IEC 60034-1	GB/T 755
旋转电动机损耗与效率确定的标准测试方法 (excluding machines for traction vehicles) Rotating electrical machines – Part 2-1: Standard methods for determining losses and efficiency from tests	IEC 60034-2	GB/T 1032
旋转电机整体结构的防护等级 (IP 代码) 分级 Rotating electrical machines – Part 5: Degrees of protection provided by the integral design of rotating electrical machines (IP code) - Classification	IEC 60034-5	GB/T 4942.1
旋转电动机冷却方法 Rotating electrical machines – Part 6: Methods of cooling (IC Code)	IEC 60034-6	GB/T 1993
旋转电动机结构型式、安装型式及接线盒位置的分类 (IM 代码) Rotating electrical machines – Part 7: Classification of types of construction, mounting arrangements and terminal box position (IM Code)	IEC 60034-7	GB/T 997
旋转电动机旋转电机线端标志与旋转方向 Rotating electrical machines – Part 8: Terminal markings and direction of rotation	IEC 60034-8	GB/T 1971
旋转电机噪声测定方法及限值 第 3 部分: 噪声限值 Rotating electrical machines – Part 9: Noise limits	IEC 60034-9	GB 10069.3
轴中心高为 56 mm 及以上电机的机械振动 振动的测量、评定及限值 Rotating electrical machines – Part 14: Mechanical vibration of certain machines with shaft heights 56 mm and higher – Measurement, evaluation and limits of vibration severity	IEC 60034-14	GB 10068
旋转电机尺寸和输出功率等级 第 1 部分: 机座号 56 ~ 400 和凸缘号 55 ~ 1080 Rotating electrical machines – Part 1: Frame numbers 56 to 400 and flange numbers 55 to 1080	IEC 60072-1	GB/T 4772.1
中小型旋转电机安全要求 Safety requirements of small and medium size rotating electrical machines		GB 14711
电气绝缘 耐热性和表示方法 Electrical insulation – Thermal evaluation and designation	IEC 60085	GB/T 11021
电工电子产品自然环境条件 温度和湿度 Classification of environmental conditions Part 2-1: Environmental conditions appearing in nature – Temperature and humidity	IEC 60721-2-1	GB/T 4797.1
标准电压 Standard voltages	IEC 60038	GB/T 156

















电动机型号 ¹⁾ Motor type

	1	2	3	4	5	6	7	8
	0	C	V	4	□	□	□	□
亚太系列 Asia pacific								
机壳材料 Housing material C = 铸铁 Cast iron								
冷却方式 Cooling method V = 空冷 ventilated								
能效等级, Energy efficiency grade 4 = 中国能效等级 2 级, IE4 效率等级 4 = China energy efficiency grade 2, IE4 efficiency								
机座号 Frame size 10 = 100; 11 = 112; 13 = 132; 16 = 160; 18 = 180; 20 = 200; 22 = 225; 25 = 250; 28 = 280; 31 = 315; 35 = 355								
铁心长 Core length								
极数 Poles A = 2; B = 4; C = 6;								

¹⁾ 电动机型号可用于能效备案及查询。

¹⁾ Motor type can be used for energy efficiency filing.

安装结构型式 Construction and mounting type

结构型式 Construction type	机座带底脚，端盖无法兰 With feet and without flange on the end-shield (DE)					
安装型式 Mounting type	IM B3 FS 100 ~ 355	IM B6 FS 100 ~ 160	IM B7 FS 100 ~ 160	IM B8 FS 100 ~ 160	IM V5 ¹⁾ FS 100 ~ 160	IM V6 ²⁾ FS 100 ~ 160
示意图 Diagram						
结构型式 Construction type	机座不带底脚，端盖有法兰 Without feet and with flange on the end-shield (DE)			机座带底脚，端盖有法兰 With feet and with flange on the end-shield (DE)		
安装型式 Mounting type	IM B5 FS 100 ~ 280	IM V1 ¹⁾³⁾ FS 100 ~ 355	IM V3 ²⁾³⁾ FS 100 ~ 160	IM B35 FS 100 ~ 355	IM V15 ¹⁾ FS 100 ~ 160	IM V35 ²⁾ FS 100 ~ 160
示意图 Diagram						
结构型式 Construction type	机座不带底脚，端盖有标准小法兰 Without feet and with C-flange on the end-shield (DE)			机座带底脚，端盖有标准小法兰 With feet and with C-flange on the end-shield (DE)		
安装型式 Mounting type	IM B14 FS 100 ~ 112	IM V18 ¹⁾ FS 100 ~ 112	IM V19 ²⁾ FS 100 ~ 112	IM B34 FS 100 ~ 112		
示意图 Diagram						

¹⁾ 室外使用时推荐使用护罩（选件号 H00）；

²⁾ 当户外安装时，推荐对电动机轴采取防护措施，避免水直接喷射到电动机轴上；

³⁾ 此安装方式中，标配全圆法兰。

¹⁾ At outdoor application, the using of protective cover (Option code H00) is recommended

²⁾ At out door application the protection of shaft again jet-water is recommended

³⁾ Full circle flange as standard configuration in this type mounting.



铭牌样例 Nameplate

1TL0004 系列电机铭牌

1TL0004 Motor Nameplate



电机配封闭式轴承铭牌样例

Example of motor with sealed bearing nameplate

  THREE-PHASE ASYNCHRONOUS MOTOR 三相异步电动机 Eff.-Grade2 GB18613-2020										
型号 0CV4104A	1TL0004-1AA42-1AA4-Z	100L	LMH-2206/600003888993/001							
220VΔ /380VY	50 Hz	10.0/5.8 A	EFF. 89.1 %	IP 55	43 kg	GB/T 755-2019				
3 kW	IM B3	2870 r/min	COSφ 0.88	Th.Cl.155(F)						
驱动端: 6206 2RZ C3 非驱动端: 6206 2RZ C3										
西门子电机(中国)有限公司 Siemens Standard Motors Ltd.										

电机配可再润滑性轴承铭牌样例

Example of motor with regreasable bearing nameplate

  THREE-PHASE ASYNCHRONOUS MOTOR 三相异步电动机 Eff.-Grade2 GB18613-2020										
型号 0CV4184C	1TL0004-1EC43-3AA4-Z	180L	LMH-2206/600003888993/001							
380VΔ /660VY	50 Hz	30.5/17.7 A	EFF. 92.9 %	IP 55	187 kg	GB/T 755-2019				
15 kW	IM B3	980 r/min	COSφ 0.80	Th.Cl.155(F)						
驱动端: 6210 C3 非驱动端: 6210 C3										
润滑脂: 2#LI Grease 油脂量: 驱动端20g / 非驱动端20g 润滑周期: 8000h										
西门子电机(中国)有限公司 Siemens Standard Motors Ltd.										

轴承系统

1TL0004 系列电动机标准配置深沟球轴承或角接触球轴承，这些轴承是密封的或可再润滑型的。

4 个缺失型号是否双端浮动？FS180 ~ 355 电动机驱动端轴承浮动，非驱动端轴承固定。

标准配置的轴承可以承受一定的悬臂力，当电动机轴端承受的悬臂力较大时，可以考虑选择增强悬臂力的轴承设计（选件号：L22）。

Bearing system

1TL0004 series motors are supplied with the ball bearing as standard. These bearings are either of the sealed or regreasable type.

For FS100 ~ 160, the floating bearings are assembled; for FS180 ~ 355, floating bearing at DE, and fixed bearing at NDE assembled.

The standard bearing can endure a maximum cantilever force, the increased cantilever bearing design (Option code: L22) should be considered.

轴承配置 Bearing Assignment

机座号 Frame size	极数 Pole	标准配置 Standard design			增强悬臂力设计轴承(选项号L22) Increased cantilever-bearing (Option code:L22)		
		驱动端轴承 DE bearing	非驱动端轴承 (水平安装) NDE bearing (Horizontal mounting)	非驱动端轴承 (立式安装) NDE bearing (Vertical mounting)	驱动端轴承 DE bearing	非驱动端轴承 (水平安装) NDE bearing (Horizontal mounting)	非驱动端轴承 (立式安装) NDE bearing (Vertical mounting)
100	2,4,6	6206 2RZ C3	6206 2RZ C3	6206 2RZ C3	6306 2RZ C3	6206 2RZ C3	6206 2RZ C3
112	2,4,6	6206 2RZ C3	6206 2RZ C3	6206 2RZ C3	6306 2RZ C3	6206 2RZ C3	6206 2RZ C3
132	2,4,6	6208 2RZ C3	6208 2RZ C3	6208 2RZ C3	6308 2RZ C3	6208 2RZ C3	6208 2RZ C3
160	2,4,6	6209 2RZ C3/6309 2RZ C3 ¹⁾	6209 2RZ C3	6209 2RZ C3	6309 2RZ C3	6209 2RZ C3	6209 2RZ C3
180	2,4,6	6210 C3	6210 C3	6210 C3	NU210	6210 C3	6210 C3
200	2,4,6	6312 C3/6212 C3 ²⁾	6212 C3	6212 C3	NU312/NU212 ²⁾	6212 C3	6212 C3
225	2,4,6	6213 C3	6213 C3	6213 C3	NU213	6213 C3	6213 C3
250	2,4,6	6215 C3	6215 C3	6215 C3	NU215	6215 C3	6215 C3
280	2,4,6	6317 C3	6217 C3	6217 C3	NU317	6217 C3	6217 C3
315	2(S/M)	6316 C3	6316 C3	6316 C3	NU316	6316 C3	6316 C3
	2(L)	6316 C4	6316 C4	7316	NU316	6316 C4	6316 C4
	4(S/M), 6	6319 C3	6319 C3	6319 C3	NU319	6319 C3	6319 C3
	4(L)	6319 C4	6319 C4	7319	NU319	6319 C4	6319 C4
355	2	6317 C3	6317 C3	7317	NU317	6317 C3	6317 C3
	4	6322 C3	6322 C3	7322	NU322	6322 C3	O.R

注：DE 驱动端
NDE 非驱动端
O.R. 须要特殊询价

¹⁾ 仅适用于1DC4

²⁾ 仅适用于2AA5

S, M, L, 1DC4 及 2AA5 描述参考第 13-17 页订货号及选型数据表详述。

Note: DE Driven end
NDE Non driven end

O.R. Possible on request

¹⁾ Only suitable for 1DC4

²⁾ Only suitable for 2AA5

The description of S, M, L, 1DC4 and 2AA5 please refer to page 13-17 order No. and technical data detailed.

润滑脂寿命和再润滑周期

对于不可再润滑的轴承，其润滑脂寿命与轴承寿命相当。但是，这只能是在电机严格按照本样本中规定的技术数据运行。

对于以规定间隔再润滑的电机，轴承寿命可以延长，从而补偿不利因素，诸如温度、安装条件、转速、轴承规格和机械载荷造成的影响。

Grease life and re-greasing interval

For permanent lubrication, the bearing grease lifetime is matched to the bearing lifetime. This can, however, only be achieved if the motor is operated in accordance with the catalog specifications.

For motors which can be regreased at defined regreasing intervals, the bearing lifetime can be extended and/or unfavorable factors such as temperature, mounting conditions, speed, bearing size and mechanical load can be compensated.

润滑脂寿命和再润滑周期（电动机水平安装） Grease life (Horizontal installation)

机座号 Frame size	极数 Poles	润滑脂寿命 : 小时(h) Grease lifetime up to CT 40 °C
持久润滑型轴承的润滑脂 Grease for permanent lubrication bearing		
100-160	2,4,6	20000或40000h
可再润滑型轴承的润滑脂 Grease for regreaseable bearing		
180-250	2	4000h
	4,6	8000h
280	2	3000h
	4,6	5000h
315	2	3000h
	4,6	4000h
355	2	3000h
	4,6	4000h

当电动机在非正常的条件下运行时，轴承的寿命会缩短。如下面几种情况：

- 当电动机的运行速度高于额定速度时，由于电动机的振动增大，使得轴承受到额外的径向力和轴向力，导致其寿命减少；
- 当环境或设备等因素引起电动机振动加大时，同样轴承也会因此受到额外的径向力和轴向力，而导致其寿命减少；
- 当环境温度每升高 10°C，润滑脂寿命以及再润滑时间缩短一半。

- When motor runs beyond the rated speed, the increase of motor vibration will result in the extra radial and axial force on bearing. This will reduce the life of bearing;
- When the motor vibration increase due to the environment or other equipment, the bearing also will endure more radial and axial force. This also will reduce the life of bearing;
- If the coolant temperature is increased by 10 °C, the grease lifetime and regreasing interval is halved.

接线盒技术参数 Connection boxes technical data

机座号 Frame size	接线螺钉螺纹 Contact screw thread	外接电缆直径 Outer cable diameter (sealing range)	进线孔尺寸 Cable entry size
100	M4	10~14	M24x1.5
112	M5	13~18	M27x2+M27x2
	M5 ¹⁾	13~18 ¹⁾	M30x2+M30x2 ¹⁾
132	M4	18~25	M32x1.5+M32x1.5
	M5 ²⁾	13~18 ²⁾	M30x2+M30x2 ²⁾
160	M5	22~32	M40x1.5+M40x1.5
	M5 ³⁾	18~25 ³⁾	M36x2+M36x2 ³⁾
180	M5	22~32	M40x1.5+M40x1.5
200	M8	22~32	M48x2+M48x2
	M6 ⁴⁾	32~38 ⁴⁾	M50x1.5+M50x1.5 ⁴⁾
225	M8	32~38	M50x1.5+M50x1.5
250	M10	37~44	M63x1.5+M63x1.5
280	M10	37~44	M64x2+M64x2
315 2P(S/M)4P(S/M)6P	M12	37~44	M64x2+M64x2
315 2P(L)4P(L)	M12	44~57	M72x2+M72x2
355	M16	38~47	M72x2+M72x2

¹⁾ 仅适用于1BB2

²⁾ 仅适用于1CC3

³⁾ 仅适用于1DC4

⁴⁾ 仅适用于2AA5

¹⁾ Only suitable for 1BB2

²⁾ Only suitable for 1CC3

³⁾ Only suitable for 1DC4

⁴⁾ Only suitable for 2AA5

振动

所有电动机转子都使用半键按照 A 级（标准）振动等级进行动态平衡。

电动机在空载时测得振动速度有效值不超过下表中的 A 级所列值。

Vibration

1TL0004 rotors are dynamically balanced to severity grade A using a half key.

Table below contains the effective vibration values for unloaded motors.

振动等级 Vibration Grade	机座号 Frame size (mm)	56 ≤ FS ≤ 132		H > 132	
		位移 Vibration displacement/μm	速度 Vibration velocity/(mm/s)	位移 Vibration displacement/μm	速度 Vibration velocity/(mm/s)
A	自由悬置 Free suspension	45	2.8	45	2.8
	刚性安装 Rigid mounting	-	-	37	2.3 2.8 ¹⁾
B	自由悬置 Free suspension	18	1.1	29	1.8
	刚性安装 Rigid mounting	-	-	24	1.5 1.8 ¹⁾

注:

¹⁾ 该值为GB/T 10068-2020 中定义的轴中心高H>132mm的两极电机，当两倍电网频率占主导时的振动速度限值。

Note:

¹⁾ The level are vibration velocity limit when the twice line frequency vibration level is dominant defined by GB/T 10068-2020, for 2p motors that frame size bigger than 132mm.

防潮加热保护

当电动机处于较为恶劣的环境时，比如湿度非常大或者昼夜温差比较大，电动机的绕组很可能出现凝露的现象，这样会带来电动机烧毁的风险。对于这种情况，建议对电动机绕组配置防潮加热带（选件号：Q04）进行保护。

电动机防潮加热带必须在电动机工作过程中处于不工作状态；当电动机停机时，防潮加热带必须启动工作，为绕组加热。防潮加热带的电气参数如下表所示。

Anti-condensation heater

Motors whose windings are at risk of condensation due to the climatic conditions, e.g. inactive motors in humid atmospheres or motors that are subjected to widely fluctuating temperatures can be equipped with anti-condensation heaters (Option code: Q04).

Anti-condensation heaters must be switched off during operation. When motor shut down, the heaters must be switched on.

防潮加热带电气参数 Electrical data of Anti-condensation heater

机座号 Frame size	功率 Power (W)	电压 Voltage (V)
100 ~ 112	30	220
132 ~ 160	40	220
180 ~ 200	50	220
225 ~ 280	60	220
315	80/100 ¹⁾	220
355	100	220

¹⁾ 适用于2P(L), 4P(L)

¹⁾ Suitable for 2P(L), 4P(L)

电气特性

额定输出

1TL0004电动机的额定功率是指电动机在连续运行的情况下 S1 (IEC 60034-1)，此时周围环境温度为 -15 °C ~ 40 °C，海拔高度不超过 1000 m。

电压、频率

IEC 60034-1 将电压和频率的偏差分为 A 类（电压偏差 ± 5 %，频率偏差 ± 2 %）和 B 类（电压偏差 ± 10 %，频率偏差 +3 % / -5 %）。电动机均能够在 A 类和 B 类提供额定转矩。在 A 类中，温度比正常运行下温度大约提升 10 K。

Electrical design

Rated Output

1TL0004 motors rated output powers means that the motor runs under continuous duty S1 (IEC 60034 - 1) operation when operated at ambient temperature from -15 °C to 40 °C and at altitudes of up to 1000 m over sea.

Voltage and Frequency

IEC 60034-1 differentiates between Category A (combination of voltage deviation ± 5 % and frequency deviation ± 2 %) and Category B (combination of voltage deviation ± 10 % and frequency deviation +3 % / -5 %) for voltage and frequency fluctuations. The motors can supply their rated torque in both Category A and B. In Category A, the temperature rise is approximately 10 K higher than during normal operation.

标准 Standard 60034 - 1	类别 Category A	类别 Category B
电压偏差 Voltage deviation	± 5 %	± 10 %
频率偏差 Frequency deviation	± 2 %	+3 % / -5 %

根据标准，不推荐电动机在 B 类情况下长时间运行
According to the standard, longer operation is not recommended for Category B.

电气数据公差

■ 效率 η

Prated ≤ 150 kW: - 0.15 x (1 - η)

Prated > 150 kW: - 0.10 x (1 - η)

效率 η 为小于 1 的值

■ 功率因数: (1 - cos φ) / 6

最小绝对值: 0.02

最大绝对值: 0.07

■ 转差率: ± 20 % (电动机的偏差 < 1 kW ± 30 % 时是允许的)

■ 堵转电流: +20 %

■ 堵转转矩: -15 % ~ +25 %

■ 最大转矩: -10 %

■ 转动惯量: ± 10 %

Tolerance for electrical data

■ Efficiency η at

Prated ≤ 150 kW: - 0.15 x (1 - η)

Prated > 150 kW: - 0.10 x (1 - η)

With η being a decimal number

■ Power factor - (1 - cos φ) / 6

Minimum absolute value: 0.02

Maximum absolute value: 0.07

■ Slip ± 20 % (for motors < 1 kW ± 30 % is admissible)

■ Locked-rotor current +20 %

■ Locked-rotor torque -15 % to +25 %

■ Breakdown torque -10 %

■ Moment of inertia ± 10 %

变频应用 Converter fed application

1TL0004 电动机适于变转速、恒转速的各种应用，如风机、泵、压缩机、纺织机械等。

1TL0004 motors are suitable for pumps, fans, compressors, textile machine and mechanical machine applications where variable or constant speed is required.

1TL0004 电动机的标准绝缘系统设计要求，能够保证其在变频器供电电压不超过 460 V 时正常运行。

The standard insulation of the 1TL0004 motors is designed such that operation is possible on the converter at mains voltage up to 460 V.

1TL0004 电动机带有特定的负载时能够使用变频器驱动，其特定的负载扭矩如以下图表所示：

1TL0004 motors are capable for converter-fed operation with certain characteristics load, of which the load torque characteristics is referred in the following diagram:

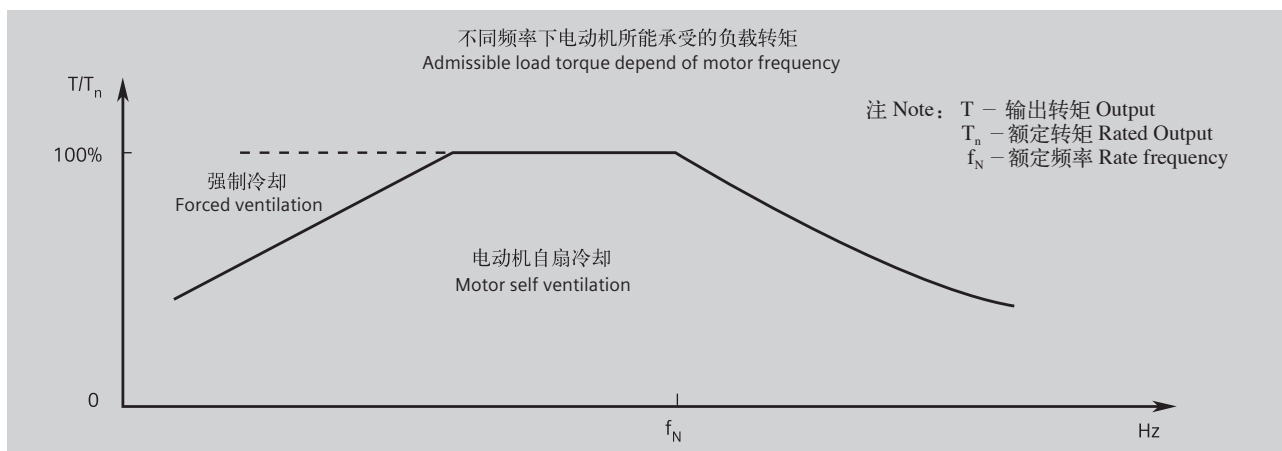

当 1TL0004 电动机变频应用（变频器供电），且输出额定功率时，电动机的使用温度等级为 155 (F)。为了避免杂散电流对电动机轴承的损坏，推荐 FS250 ~ 355 电动机使用绝缘轴承。请向西门子咨询关于绝缘轴承的详细信息。

At rated output with converter fed operation, the motors will be used in temperature class 155 (F). To prevent damage as a result of bearing currents, insulated bearings are recommended to be assembled for frame size 250 and above. Please inquire Siemens about the detailed information of insulated bearing.

当负载扭矩在允许的转矩范围内时，电动机能够自扇冷却；当负载扭矩超过所允许的转矩时，电动机需要强迫冷却。

By usage with admissible torque and below, the motor can be operated with self cooling; by usage over the admissible torque line, the motor with forced ventilation is needed.

在电动机运行速度超过额定转速时，噪声和振动值将增加，并且轴承的寿命将缩短。需要注意再润滑周期和润滑脂的寿命。

At operating speeds above rated speed the noise and vibration levels increase and the bearing life time reduce. Attention should be paid to the re-greasing intervals and the grease service life.

1TL0004 电动机所允许的最大安全转速如下表

The allowed maximum safe operating speed of 1TL0004 motors shows the diagram

机座号 Frame size	2 极 2 pole		4 极 4 pole		6 极 6 pole	
	最高转速 Max.rpm	最大频率 fmax	最高转速 Max.rpm	最大频率 fmax	最高转速 Max.rpm	最大频率 fmax
100	5200	87	3600	120	2400	120
112	5200	87	3600	120	2400	120
132	4500	75	2700	90	2400	120
160	4500	75	2700	90	2400	120
180	4500	75	2700	90	2400	120
200	4500	75	2300	77	1800	90
225	3600	60	2300	77	1800	90
250	3600	60	2300	77	1800	90
280	3600	60	2300	77	1800	90
315	3600	60	2300	77	1800	90
355	3600	60	2300	77	1800	90

独立驱动风扇技术参数 Technical data for separately fan

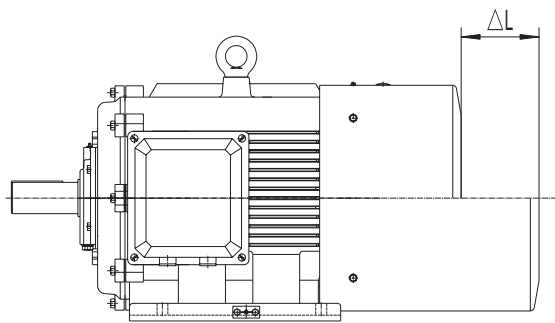

独立驱动风扇技术参数 Technical data for separately fan

对应电动机机座号 Motor frame size	额定电压 (V) rated voltage	额定频率 (Hz) Rated frequency	功率 (W) Rated output	电流 (A) Current	ΔL
100	220D/380Y	50	52	0.21/0.12	65
			65 ¹⁾	0.31/0.18 ¹⁾	65 ¹⁾
112			52	0.21/0.12	75
			80 ²⁾	0.31/0.18 ²⁾	65 ²⁾
132			45	0.35/0.2	75
			55 ³⁾	0.22/0.13 ³⁾	70 ³⁾
160			45	0.35/0.2	55
			60 ⁴⁾	0.35/0.20 ⁴⁾	125 ⁴⁾
180			120	1.04/0.6	65
200			120	1.04/0.6	60/65 ⁵⁾
225			120	1.04/0.6	60
250			230	1.73/1.0	80
280			230	1.73/1.0	105
315 2P (S/M) 4P (S/M) 6P			370	1.91/1.1	95
315 2P (L) 4P (L)			1100	4.33/2.5	180
355			550	2.18/1.26	100

注： 风扇可以在 210 ~ 240VD/360 ~ 420VY 50Hz 电源供电下运行，也可以在 220 ~ 260VD/380 ~ 480VY 60Hz 电源供电下运行。其他电源供电，须特殊询价。

¹⁾ 仅适用于 1AB5

²⁾ 仅适用于 1BB2

³⁾ 仅适用于 1CC3

⁴⁾ 仅适用于 1DC4

⁵⁾ 仅适用于 2AA5

Note: The fan can be running with supply 210 ~ 240VD/360 ~ 420VY 50Hz, and also 220 ~ 260VD/380 ~ 480VY 60Hz. Other voltage supply, possible on request.

¹⁾ Only suitable for 1AB5

²⁾ Only suitable for 1BB2

³⁾ Only suitable for 1CC3

⁴⁾ Only suitable for 1DC4

⁵⁾ Only suitable for 2AA5

订货号 Order No.

电动机订货号

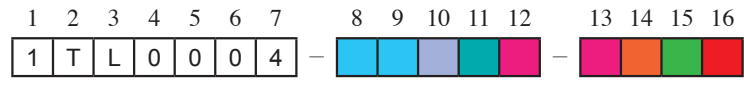

低压系列电动机 Low-voltage motor series

0= 铸铁壳
0=Cast Iron

效率等级 Efficiency Grade

4 = 中国能效等级 2 级, IE4 效率等级
4 = China energy efficiency grade 2, IE4 efficiency

机座号编号 Code of frame size

1A = 100 / 1B = 112 / 1C = 132 / 1D = 160 / 1E = 180
2A = 200 / 2B = 225 / 2C = 250 / 2D = 280
3A = 315 / 3B = 355

极数编号 Code of poles

A = 2 / B = 4 / C = 6

机座长度编号 Code of frame length

0 or 1 = S (short) / 2 or 3 or 4 = M (medium) / 4 or 5 or 6 or 7 = L (long)

电压, 连接方式和频率编号 Code of voltage, connections and frequency

04 = 400VD 50Hz
22⁹⁾ = 230VD / 400VY 50Hz 35 = 415VD 50Hz
21⁹⁾ = 220VD / 380VY 50Hz 23⁹⁾ = 240VD / 415VY 50Hz 90¹⁾ = 特殊电压与频率 special voltage & frequency
33 = 380VD / 660VY 50Hz 34 = 400VD / 690VY 50Hz

结构和安装方式编号 Code of Construction and mounting type

T²⁾ = IM B6
A²⁾ = IM B3 U²⁾ = IM B7 W⁵⁾ = IM V15 M^{3) 4) 5)} = IM V18
J²⁾ = IM B35 V²⁾ = IM B8 Y = IM V35 L⁵⁾ = IM V19
F^{2) 3)} = IM B5 C⁵⁾ = IM V5 G^{3) 5)} = IM V1 N^{2) 4)} = IM B34
K^{2) 3) 4)} = IM B14 D = IM V6 H³⁾ = IM V3

绕组保护编号 Code of winding protection

A = 无绕组保护 without winding protection
B⁶⁾ = 绕组带 3 个 PTC 热敏电阻用于跳闸 3 PTC thermistors for tripping
C⁶⁾ = 绕组带 6 个 PTC 热敏电阻用于报警和跳闸 6 PTC thermistors for alarm and tripping
H⁶⁾⁷⁾ = 绕组带 3 个 Pt100 测温元件 3 resistance thermometers Pt100
J⁶⁾⁷⁾ = 绕组带 6 个 Pt100 测温元件 6 resistance thermometers Pt100
Z⁸⁾ = 其他绕组保护 Other temperature for winding protection

接线盒位置编号 (从驱动端看) Code location of connection box (view from drive end)

4 = 顶端出线 top / 5 = 右端出线 on RHS / 6 = 左端出线 on LHS

附注:

- 1) 用电压编号 90 及相应选件号来定制其它电压 (参见选件描述) ;
- 2) 铭牌上标有结构型式。若需要冷凝水排放孔 (订货号: H03) , 则必须指明电机的安装结构型式, 以便在制造过程中确定冷凝水排放孔的具体位置;
- 3) 对于 IM B5、IM V1、IM V3、IM B14、IM V18 和 IM V19 安装结构型式电动机, 须指定电动机订货号第 16 位数字为“4”;
- 4) 只适用于 FS100 ~ 112;
- 5) 电动机标配无防雨罩, 但如需要加带防雨罩用于防护时, 须订购选件号 H00;
- 6) 选择此选件, 接线盒将更改为铸铁壳;
- 7) 仅适用于机座号 100-355;
- 8) 请向西门子另行咨询;
- 9) 不适用于 FS315 ~ 355 电机。

订货号样例:

2 级能效低压三相异步电动机

4 极, 15 kW, IM B3, 380VD / 660VY 50 Hz, IP55, 接线盒位置处于右侧, 进线孔向下 (从驱动端看)。

电动机订货号: 1TL0004-1DB43-3AA5

Foot note:

- 1) Order other voltages with voltage code 90 and the corresponding Option code (see under "Option") .
- 2) The type of construction is stamped on the rating plate. When ordering with condensation drainage holes (order code H03), it is absolutely necessary to specify the type of construction for the exact position of the condensation drainage holes during manufacture.
- 3) For motor with IM B5, IM V1, IM V3, IM B14, IM V18 and IM V19 construction and mounting type, the 16th digit of motor order No. must be "4";
- 4) Only for FS100 ~ 112.
- 5) Without canopy, for protective cover with canopy needed Option code H00.
- 6) Choose this option, the connection box will be changed to cast iron.
- 7) Only applicable for frame size 100-355.
- 8) Please specially consult with Siemens.
- 9) Not applicable for FS315 ~ 355 motors.

Order No. example:

China Energy Efficiency Grade2 low voltage three phase asynchronous motor

4-pole, 15 kW, IM B3, 380VD/660VY 50 Hz, IP55, connection box at right side and cable entry at bottom (view from DE)

Motor order code: 1TL0004-1DB43-3AA5

1	T	L	0	0	0	4	-	1	D	B	4	3	-	3	A	A	5
---	---	---	---	---	---	---	---	---	---	---	---	---	---	---	---	---	---

2 级能效铸铁低压三相异步电动机
China Energy Efficiency Grade2 Cast Iron
Low-voltage Three-phase Motor

机座号 Frame size: 160

极数 Poles: 4

铁心长度 Iron core length: 长机座 (L)

电压, 连接方式和频率 Voltage, connection method and frequency: 380VD/660VY 50Hz

结构型式 Construction: IM B3

绕组保护 Winding protection None: 无

接线盒位置 Connection box position at right side: 右侧

选型技术数据表 Technical data table

铸铁壳系列电机 Cast Iron Motors

中国能效等级2级, IE4

机座号 Frame Size	额定 功率 Rate Output 50 Hz	电动机 型号 Motor type	订货号 Order No.	额定 转速 Rated Speed	效率 — 参照 GB18613-2020 效率等级 2 Efficiency is in accordance with the efficiency level 2 of GB18613-2020				额定 转矩 Rated torque	起动 电流 / 额定 电流 Starting current /Rated current	起动 转矩 / 额定 转矩 Starting torque/ Rated torque	最大 转矩 / 额定 转矩 Max torque / Rated torque	转动 惯量 Moment of Inertia	重量 IMB3 Weight	噪声 Noise
					效率 (100% 负载) Efficiency at (50 Hz) 4/4 load	效率 (75% 负载) Efficiency at (50 Hz) 3/4 load	功率 因数 Power factor	额定 电流 Rated current							
3000rpm 2 极 2-pole															
220VD/380VY 50HZ															
100L	3	0CV4104A	1TL0004-1AA42-1 □□□□	2870	89.1	90.5	0.88	5.8	10.0	8.0	3.6	4.0	0.0052	41	62
3000rpm 2 极 2-pole															
380VD / 660VY 50HZ															
112M	4	0CV4112A	1TL0004-1BA23-3 □□□□	2930	90.0	90.9	0.91	7.4	13.0	9.5	3.0	3.6	0.0142	49	65
132S	5.5	0CV4130A	1TL0004-1CA03-3 □□□□	2940	90.9	91.7	0.88	10.4	17.9	9.0	3.0	4.0	0.0174	61	67
132S	7.5	0CV4131A	1TL0004-1CA13-3 □□□□	2935	91.7	92.7	0.90	13.8	24.4	9.0	3.0	4.0	0.0218	69	67
160M	11	0CV4162A	1TL0004-1DA23-3 □□□□	2955	92.6	93.1	0.88	20.5	35.5	9.0	3.0	4.0	0.0449	111	69
160M	15	0CV4163A	1TL0004-1DA33-3 □□□□	2945	93.3	93.8	0.86	28.5	48.6	9.0	3.0	4.0	0.0449	111	69
160L	18.5	0CV4164A	1TL0004-1DA43-3 □□□□	2945	93.7	94.3	0.88	34.0	60.0	9.0	3.0	4.0	0.0536	132	69
180M	22	0CV4182A	1TL0004-1EA23-3 □□□□	2960	94.0	94.2	0.89	40.0	71.0	9.5	2.6	3.6	0.0905	178	70
200L	30	0CV4204A	1TL0004-2AA43-3 □□□□	2960	94.5	94.7	0.88	55	96.8	8.0	2.6	3.6	0.166	247	71
200L	37	0CV4205A	1TL0004-2AA53-3 □□□□	2960	94.8	95.0	0.88	67	119	8.5	3.0	3.6	0.1930	277	71
225M	45	0CV4222A	1TL0004-2BA23-3 □□□□	2970	95.0	95.1	0.89	81	145	8.5	3.0	3.4	0.322	363	72
250M	55	0CV4252A	1TL0004-2CA23-3 □□□□	2980	95.3	95.3	0.88	100	176	8.3	3.0	3.4	0.523	420	75
280S	75	0CV4280A	1TL0004-2DA03-3 □□□□	2980	95.6	95.5	0.89	134	240	8.5	3.0	3.4	0.9298	508	77
280M	90	0CV4282A	1TL0004-2DA23-3 □□□□	2980	95.8	95.8	0.89	160	288	8.5	3.0	3.4	1.0255	555	77
315S	110	0CV4310A	1TL0004-3AA03-3 □□□□	2985	96.0	96.0	0.90	193	352	7.9	2.3	2.6	1.6429	800	78
315M	132	0CV4312A	1TL0004-3AA23-3 □□□□	2986	96.2	96.1	0.90	230	422	9.0	3.0	3.2	1.9615	900	78
315L	160	0CV4315A	1TL0004-3AA53-3 □□□□	2982	96.3	96.3	0.89	285	512	8.2	2.6	3.0	2.46	1285	81
315L	185	0CV4316A	1TL0004-3AA63-3 □□□□	2980	96.4	96.4	0.89	330	593	8.2	2.6	3.0	2.80	1361	81
315L	200	0CV4317A	1TL0004-3AA73-3 □□□□	2980	96.5	96.7	0.89	355	641	8.0	2.6	3.0	2.80	1378	81
355M	220	0CV4352A	1TL0004-3BA23-3 □□□□	2988	96.5	96.2	0.90	385	703	8.5	2.5	3.0	2.75	1515	85
355M	250	0CV4353A	1TL0004-3BA33-3 □□□□	2985	96.5	96.4	0.91	435	800	8.0	2.5	3.0	2.75	1510	85
355L	280	0CV4355A	1TL0004-3BA53-3 □□□□	2986	96.5	96.5	0.91	485	896	8.5	2.2	2.8	3.28	1620	85
355L	315	0CV4356A	1TL0004-3BA63-3 □□□□	2982	96.5	96.6	0.91	550	1009	8.0	2.2	2.8	3.28	1635	85

注：
¹⁾ 关于其他电压与频率、绕组保护及接线盒位置的编码，请见第 14 页“订货号”部分；
²⁾ 噪声值仅适用于电动机在 50 Hz 电源直接供电且空载运行时的情况，容差为 +3 dB。

Note:
¹⁾ About the code of other voltage and frequency, winding protection and connection box position, please refer to Orde No. in page 14.
²⁾ Noise value is only applicable to the direct power supply of the motor in 50Hz power supply and the condition of no-load operation, the tolerance is +3dB.

选型技术数据表 Technical data table

铸铁壳系列电机 Cast Iron Motors

中国能效等级2级, IE4

机座号 Frame Size	额定 功率 Rate Output 50 Hz	电动机 型号 Motor type	订货号 Order No.	额定 转速 Rated Speed	效率 — 参照 GB18613-2020 效率等级 2 Efficiency is in accordance with the efficiency level 2 of GB18613-2020				额定 转矩 Rated torque	起动 电流 / 额定 电流 Starting current /Rated current	起动 转矩 / 额定 转矩 Starting torque/ Rated torque	最大 转矩 / 额定 转矩 Max torque / Rated torque	转动 惯量 Moment of Inertia	重量 IMB3 Weight	噪声 Noise
					效率 (100% 负载) Efficiency at (50 Hz) 4/4 load	效率 (75% 负载) Efficiency at (50 Hz) 3/4 load	功率 因数 Power factor	额定 电流 Rated current							
1500rpm 4 极 4-pole															
220VD/380VY 50HZ															
100L	2.2	0CV4104B	1TL0004-1AB42-1 □□□	1455	89.5	90.0	0.79	4.75	14.4	9.0	3.6	4.0	0.0125	42	52
100L	3	0CV4105B	1TL0004-1AB52-1 □□□	1455	90.4	89.8	0.80	6.3	19.7	9.0	2.7	3.3	0.0156	48	54
1500rpm 4 极 4-pole															
380VD / 660VY 50HZ															
112M	4	0CV4112B	1TL0004-1BB23-3 □□□	1465	91.1	91.2	0.80	8.34	26.1	9.5	2.7	3.3	0.0223	56	60
132S	5.5	0CV4130B	1TL0004-1CB03-3 □□□	1460	91.9	92.4	0.80	11.4	36.0	9.0	3.2	4.0	0.0305	75	63
132M	7.5	0CV4132B	1TL0004-1CB23-3 □□□	1465	92.6	93.3	0.80	15.4	48.9	9.5	3.2	4.0	0.0381	88	63
160M	11	0CV4162B	1TL0004-1DB23-3 □□□	1470	93.3	93.8	0.83	21.5	71.5	9.5	3.0	4.0	0.0683	114	61
160L	15	0CV4164B	1TL0004-1DB43-3 □□□	1470	93.9	94.4	0.84	29.0	97.4	9.5	3.0	4.0	0.0902	144	61
180M	18.5	0CV4182B	1TL0004-1EB23-3 □□□	1475	94.2	94.8	0.83	36.0	120	8.5	3.0	3.6	0.1531	182	63
180L	22	0CV4184B	1TL0004-1EB43-3 □□□	1475	94.5	95.0	0.82	43.0	142	9.0	3.0	3.6	0.1724	201	63
200L	30	0CV4204B	1TL0004-2AB43-3 □□□	1478	94.9	95.4	0.84	57	194	9.0	3.0	3.6	0.2812	265	63
225S	37	0CV4220B	1TL0004-2BB03-3 □□□	1485	95.2	95.6	0.85	69	238	8.5	3.0	3.3	0.543	332	65
225M	45	0CV4222B	1TL0004-2BB23-3 □□□	1485	95.4	95.7	0.83	86	289	9.0	3.3	3.6	0.586	356	65
250M	55	0CV4252B	1TL0004-2CB23-3 □□□	1488	95.7	96.0	0.85	103	353	9.0	3.3	3.6	1.031	471	66
280S	75	0CV4280B	1TL0004-2DB03-3 □□□	1488	96.0	96.2	0.86	138	481	8.5	3.0	3.2	1.5996	553	66
280M	90	0CV4282B	1TL0004-2DB23-3 □□□	1488	96.1	96.4	0.86	165	578	8.5	3.0	3.2	1.9621	641	66
315S	110	0CV4310B	1TL0004-3AB03-3 □□□	1490	96.3	96.5	0.88	197	705	8.5	3.0	3.0	2.9087	835	74
315M	132	0CV4312B	1TL0004-3AB23-3 □□□	1490	96.4	96.7	0.89	235	846	8.5	3.0	3.0	3.6589	970	74
315L	160	0CV4315B	1TL0004-3AB53-3 □□□	1490	96.6	96.9	0.87	290	1026	7.6	2.0	2.4	4.01	1370	74
315L	185	0CV4316B	1TL0004-3AB63-3 □□□	1490	96.7	96.9	0.87	335	1186	7.6	2.0	2.4	4.44	1430	74
315L	200	0CV4317B	1TL0004-3AB73-3 □□□	1490	96.7	96.9	0.87	360	1282	7.6	2.0	2.4	4.69	1451	74
355M	220	0CV4352B	1TL0004-3BB23-3 □□□	1491	96.7	97.0	0.90	385	1409	8.0	1.8	3.2	5.50	1720	81
355M	250	0CV4353B	1TL0004-3BB33-3 □□□	1492	96.7	96.9	0.90	435	1600	8.0	1.8	2.9	5.99	1800	81
355L	280	0CV4355B	1TL0004-3BB53-3 □□□	1492	96.7	96.9	0.90	490	1792	8.0	1.8	2.9	5.99	1795	81
355L	315	0CV4356B	1TL0004-3BB63-3 □□□	1490	96.7	97.1	0.90	550	2019	8.0	1.8	2.9	6.18	1865	81

注：
 1) 关于其他电压与频率、绕组保护及接线盒位置的编码，请见第 14 页“订货号”部分；
 2) 噪声值仅适用于电动机在 50 Hz 电源直接供电且空载运行时的情况，容差为 +3 dB。

Note:
 1) About the code of other voltage and frequency, winding protection and connection box position, please refer to Orde No. in page 14.
 2) Noise value is only applicable to the direct power supply of the motor in 50Hz power supply and the condition of no-load operation, the tolerance is +3dB.

选型技术数据表 Technical data table

铸铁壳系列电机 Cast Iron Motors

中国能效等级2级, IE4

机座号 Frame Size	额定 功率 Rate Output 50 Hz	电动机 型号 Motor type	订货号 Order No.	额定 转速 Rated Speed	效率 — 参照 GB18613-2020 效率等级 2 Efficiency is in accordance with the efficiency level 2 of GB18613-2020				额定 转矩 Rated torque	起动 电流 / 额定 电流 Starting current /Rated current	起动 转矩 / 额定 转矩 Starting torque/ Rated torque	最大 转矩 / 额定 转矩 Max torque / Rated torque	转动 惯量 Moment of Inertia	重量 IMB3 Weight	噪声 Noise
					效率 (100% 负载) Efficiency at (50 Hz) 4/4 load	效率 (75% 负载) Efficiency at (50 Hz) 3/4 load	功率 因数 Power factor	额定 电流 Rated current							
	kW	rpm	%	%		A	Nm	I_{LR}/I_{rated}	T_{LR}/T_{rated}	T_{max}/T_{rated}	kgm ²	kg	L _{pA}		
1000rpm 6极															
220VD/380VY 50HZ															
100L	1.5	0CV410C4	1TL0004-1AC42-1 □□□	960	85.9	86.2	0.71	3.75	14.9	6.5	2.8	3.0	0.0128	43	49
112M	2.2	0CV4112C	1TL0004-1BC22-1 □□□	960	87.4	88.0	0.71	5.4	21.9	7.0	3.2	3.4	0.0152	50	53
132S	3	0CV4130C	1TL0004-1CC02-1 □□□	970	88.6	89.2	0.71	7.3	29.5	7.0	2.7	4.0	0.0256	66	57
1000rpm 6极															
380VD / 660VY 50HZ															
132M	4	0CV4132C	1TL0004-1CC23-3 □□□	970	89.5	90.0	0.72	9.4	39.4	7.0	2.7	4.0	0.0402	88	57
132M	5.5	0CV4133C	1TL0004-1CC33-3 □□□	968	90.5	89.9	0.72	12.8	54.3	9.0	2.3	2.6	0.0569	99	61
160M	7.5	0CV4162C	1TL0004-1DC23-3 □□□	985	91.3	91.5	0.76	16.4	72.7	7.5	3.0	3.0	0.1337	118	61
160L	11	0CV4164C	1TL0004-1DC43-3 □□□	980	92.3	91.8	0.77	23.5	107	8.5	2.2	2.5	0.1580	157	61
180L	15	0CV4184C	1TL0004-1EC43-3 □□□	980	92.9	93.8	0.80	30.5	146	7.0	2.3	3.0	0.2413	187	59
200L	18.5	0CV4204C	1TL0004-2AC43-3 □□□	982	93.4	94.1	0.80	37.5	180	7.0	2.3	3.0	0.3521	218	59
200L	22	0CV4205C	1TL0004-2AC53-3 □□□	982	93.7	94.3	0.80	44.5	214	8.0	2.8	3.2	0.4143	259	59
225M	30	0CV4222C	1TL0004-2BC23-3 □□□	985	94.2	94.7	0.81	60	291	8.3	3.0	3.5	0.779	353	60
250M	37	0CV4252C	1TL0004-2CC23-3 □□□	986	94.5	95.2	0.83	72	358	8.0	2.8	3.2	1.581	468	65
280S	45	0CV4280C	1TL0004-2DC03-3 □□□	988	94.8	95.4	0.83	87	435	8.5	3.2	3.2	1.4206	460	64
280M	55	0CV4282C	1TL0004-2DC23-3 □□□	988	95.1	95.7	0.84	105	532	8.5	3.6	3.6	2.0212	568	64
315S	75	0CV4310C	1TL0004-3AC03-3 □□□	991	95.4	95.7	0.84	142	723	7.8	2.4	3.0	2.85	792	69
315M	90	0CV4312C	1TL0004-3AC23-3 □□□	990	95.6	95.9	0.84	170	868	7.8	2.4	3.0	3.02	955	69
315L	110	0CV4315C	1TL0004-3AC53-3 □□□	990	95.8	96.2	0.85	205	1061	8.0	2.4	3.0	4.33	1090	69
315L	132	0CV4316C	1TL0004-3AC63-3 □□□	990	96.0	96.4	0.84	250	1273	8.5	3.0	3.0	4.65	1134	69
355M	160	0CV4352C	1TL0004-3BC23-3 □□□	993	96.2	96.4	0.86	295	1539	7.5	2.2	2.8	9.91	1690	71
355M	185	0CV4353C	1TL0004-3BC33-3 □□□	993	96.3	96.5	0.86	340	1779	7.5	2.2	2.8	10.46	1730	71
355M	200	0CV4354C	1TL0004-3BC43-3 □□□	993	96.3	96.5	0.86	365	1923	8.0	2.2	2.8	10.83	1760	71
355L	220	0CV4355C	1TL0004-3BC53-3 □□□	993	96.4	96.6	0.86	405	2116	8.0	2.4	3.0	11.57	1815	71
355L	250	0CV4356C	1TL0004-3BC63-3 □□□	993	96.5	96.8	0.86	460	2404	8.0	2.4	3.0	12.78	1940	71

注:

¹⁾ 关于其他电压与频率、绕组保护及接线盒位置的编码, 请见第 14 页“订货号”部分;

²⁾ 噪声值仅适用于电动机在 50 Hz 电源直接供电且空载运行时的情况, 容差为 +3 dB。

Note:

¹⁾ About the code of other voltage and frequency, winding protection and connection box position, please refer to Orde No. in page 14.

²⁾ Noise value is only applicable to the direct power supply of the motor in 50Hz power supply and the condition of no-load operation, the tolerance is +3dB.

选件 Options

电动机订货号 Motor order code	选件号 ¹⁾ Option Code	描述 Description	应用范围 Application Scope
电压与频率 Voltages and frequency			
1TL0004- □□□□ 2-1 □□□□	—	220 VD / 380 VY 50 Hz (1.5 kW ~ 3 kW ²⁾)	FS100 ~ 280
1TL0004- □□□□ 3-3 □□□□	—	380 VD / 660 VY 50 Hz (4 kW ~ 315 kW ²⁾)	FS100 ~ 355
1TL0004- □□□□ 2-2 □□□□	—	230 VD / 400 VY 50 Hz	FS100 ~ 280
1TL0004- □□□□ 3-4 □□□□	—	400 VD / 690 VY 50 Hz	FS100 ~ 355
1TL0004- □□□□ 2-3 □□□□	—	240 VD / 415 VY 50 Hz	FS100 ~ 280
1TL0004- □□□□ 0-4 □□□□	—	400 VD 50 Hz	FS100 ~ 355
1TL0004- □□□□ 3-5 □□□□	—	415 VD 50 Hz	FS100 ~ 355
1TL0004- □□□□ 9-0 □□□□	M2B ¹²⁾	380VD/660VY 60Hz, 50Hz 功率输出 power output	FS100 ~ 355
	M2D ¹²⁾	440VD 60Hz, 50Hz 功率输出 power output	FS100 ~ 355
	M2F ¹²⁾	460VD 60Hz, 50Hz 功率输出 power output	FS100 ~ 355
绕组保护 Motor protection			
1TL0004- □□□□□□ - □□ A □ ²⁾	—	无绕组保护 Without motor protection	FS100 ~ 355
1TL0004- □□□□□□ - □□ B □	—	绕组带一组三芯串联的 PTC 热敏电阻用于跳闸 Motor protection with PTC thermistors with three embedded temperature sensors for tripping	FS100 ~ 355
1TL0004- □□□□□□ - □□ C □	—	绕组带两组三芯串联的 PTC 热敏电阻用于报警和跳闸 Motor protection with PTC thermistors with six embedded temperature sensors for alarm & tripping	FS100 ~ 355
1TL0004- □□□□□□ - □□ H □	—	绕组带 3 个 Pt100 测温元件 Installation of three PT100 resistance thermometers	FS100 ~ 355
1TL0004- □□□□□□ - □□ J □	—	绕组带 6 个 Pt100 测温元件 Installation of six PT100 resistance thermometers	FS100 ~ 355
线圈和绝缘 Windings and insulation			
—	N01 ⁸⁾	温度等级 155 (F), 使用 155 (F), 带有服务系数 (SF1.15) Temperature class 155 (F), used according to 155 (F), with service factor (SF1.15)	FS100 ~ 355
—	N10	180 (H) 度温度等级绝缘 Temperature class 180 (H)	FS100 ~ 355
—	Q04 ³⁾	绕组带 220 V 防潮加热带 Anti-condensation heater for 220 VAC (spaces heater)	FS100 ~ 355
电动机接线盒 Motor connection box			
—	R10 ⁴⁾	接线盒直接旋转 90°, 进线口朝向驱动端 Rotation of the connection box through 90°, entry from DE	FS100 ~ 355
—	R11 ⁵⁾	接线盒直接旋转 90°, 进线口朝向非驱动端 Rotation of the connection box through 90°, entry from NDE	FS100 ~ 355
—	R12	接线盒直接旋转 180° Rotation of the connection box through 180°	FS100 ~ 355
—	H04	外部接地 external earthing	FS100 ~ 280
—	X07	铸铁接线盒 cast iron connection box	FS100 ~ 355
—	X47	电机接线盒标配 2 个自锁葛兰 Connection boxes of the motors include 2 self-locking cable gland	FS112 ~ 355

¹⁾ 订货时, 电动机订货号需带“-Z”, 另外附上选件号;

²⁾ 无需附加费用;

³⁾ 选择此选件, 接线盒将更改为铸铁壳

⁴⁾ 不适用 FS100-112 及 1CC3 法兰安装电机, 且不能与选件 H08 共同使用;

⁵⁾ 不适用于顶出线;

⁶⁾ H00、F70 均不能与此选件并用;

⁷⁾ 非驱动端上的第二轴伸尺寸见外形尺寸;

¹⁾ Order No. supplement Z with option code when ordering.

²⁾ Without additional charge.

³⁾ When choose these options, the connection boxes will be changed to cast iron shell.

⁴⁾ Not applicable to the FS100-112 and 1CC3 flange mounted motors, and can't be used with the option H08.

⁵⁾ Not applicable to the outlet on top.

⁶⁾ H00、F70 can't be used with this option.

⁷⁾ Second standard shaft extension on NDE is shown in the dimension drawings.

选件 Options

电动机订货号 Motor order code	选件号 ¹⁾ Option Code	描述 Description	应用范围 Application Scope
轴承 Bearings			
—	Q72	轴承带两个 PT100 测温元件 Installation of 2PT100 screw-in resistance thermometers for bearing	FS180 ~ 355
—	L80	SKF 轴承 SKF Bearing	FS100 ~ 355
—	L81	其他进口品牌轴承 Other imported brand bearings	FS100 ~ 355
—	L20 ¹³⁾	驱动端轴承固定 Located bearing at DE	FS100 ~ 160
—	L22 ¹³⁾¹⁴⁾	增强悬臂力 Increased cantilever forces	FS100 ~ 355
机械设计和防护等级 Mechanical design and degrees of protection			
—	X17 ⁶⁾⁷⁾	第二标准轴伸 Second standard shaft extension	FS100 ~ 355
—	H22	IP56 防护等级 (非高海况) IP56 degree of protection (non-heavy-sea)	FS100 ~ 355
—	H00 ⁹⁾	电动机带防护罩 Motor with protective cover	FS100 ~ 355
—	H03 ¹⁰⁾	排水孔 Drainage holes	FS100 ~ 355
—	F90 ¹¹⁾	风机电机 (无风扇风罩, 非驱动端全封闭) Fan motor(no fan cover, NDE fully enclosed)	FS100 ~ 355
—	D03	用于环境温度 -40 °C ~ +40 °C 下使用的电机 Applicable to the motors that is used in the coolant temperature of -40°C~+40°C	FS100 ~ 355
—	F70 ⁹⁾	电动机带独立驱动风扇 Motors with the independent drive fan	FS100 ~ 355
铭牌和测试证书 Rating plate and test certificates			
—	B80	出厂检验报告 Acceptance test certificate 3.1 in accordance with EN 10204	FS100 ~ 355
喷漆 Paint finish			
—	S01	不喷漆, 只带底漆 Unpainted, only primed	FS100 ~ 355
—	W88	适用 TH, W, F1, WF1 以及海洋性气候环境用电机 Design for TH, W, F1, WF1 and Sea air resistant	FS100 ~ 355
包装 Packing			
—	B90	包装 (FS80 ~ 132 电动机采用纸箱包装, FS160 ~ 355 电动机采用木箱包装) Packing(FS80~132 motors adopt the carton packaging, FS160~355 motors adopt the wooden cases packaging)	FS100 ~ 355

⁸⁾ 不可变频使用;

⁹⁾ 无法与选件号 X17 并用;

¹⁰⁾ 仅适用于水平安装的电动机。对于 IM B5 和 IM B14 安装结构型式的电动机, 选择此选件时, 必须确保接线盒处于机座顶端。对于其它安装结构型式的电机请咨询西门子;

¹¹⁾ 无风扇和风罩时, 电动机的长度将减小。如需要按照铭牌上功率数值输出时电动机需要外部冷却。客户应当采用正确的冷却方式, 没有或错误的冷却方式都将减少电动机的使用寿命, 甚至会损坏电动机;

¹²⁾ 根据国标要求, 60Hz 频率下不考核能效要求;

¹³⁾ FS 180-355, L20 与 L22 不能同时选用;

¹⁴⁾ 不适用于 1AB5, 1BB2 及 1DC4。

⁸⁾ Can not be use in VSD application.

⁹⁾ Unable to be used with the option X17.

¹⁰⁾ Only applicable to the vertical mounting motors. For the construction type of IM B5 and IM B14, when choose this option, it is necessary to ensure the connection box is on top of the frame. For other construction types, please specially consult with SIEMENS.

¹¹⁾ When without the fans or the shells, the motor length will be decreased by. If it is necessary to output according to the nameplate power, the motor requires external cooling. Customers are supposed to adopt the right cooling method, without or wrong cooling methods will decrease the service life for the motors. even damage the motors.

¹²⁾ According to the requirements of the GB, the energy efficiency requirement is not evaluated under the frequency of 60Hz.

¹³⁾ For FS 180-355, L20+L22 can't be selected.

¹⁴⁾ Not suitable for 1AB5, 1BB2 and 1DC4.

外形尺寸 Dimension drawings

1TL0004 铸铁系列电机 Cast-iron series 1TL0004

机座号从 100L~355L Frame sizes 100L to 355L

IM B3 安装结构方式 Type of construction IM B3

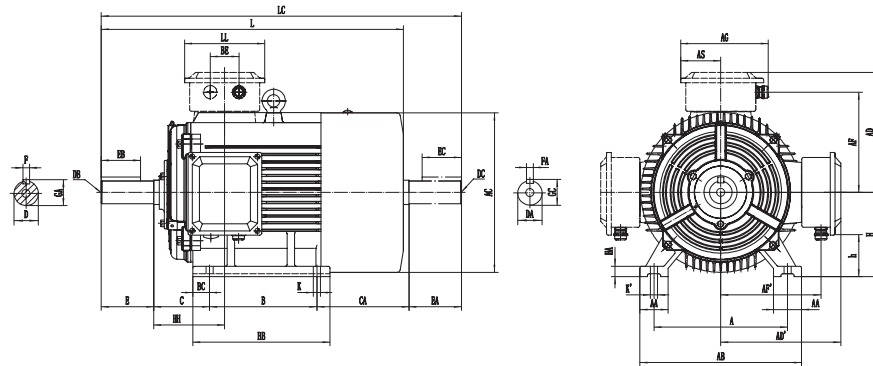

IM B35 安装结构方式 Type of construction IM B35

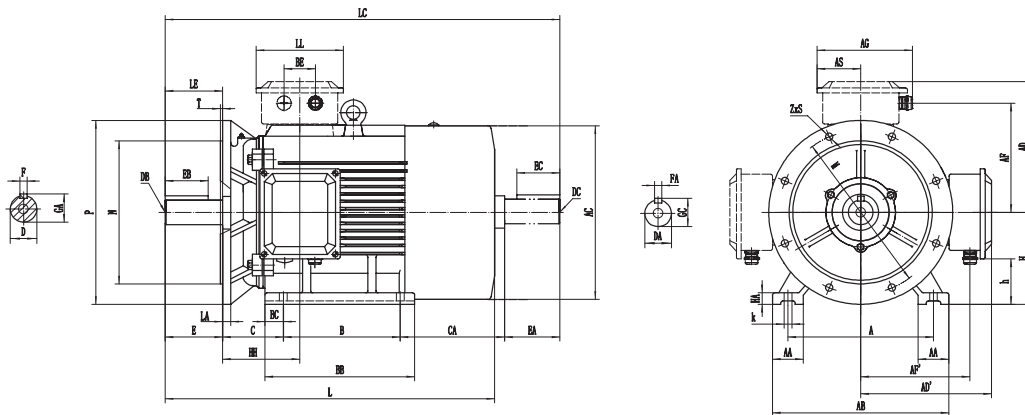

机座号 Frame size	类型 Type 1TL0004-	极数 Poles	尺寸图依据 IEC 标准 Dimension designation according to IEC standards									
			A	AA	AB	AC ¹⁾	AD / AD'	AF / AF'	AG	AH	AS	B ²⁾
100L	1A□4	2,4,6	160	40	200	196	165	135	135	-	55	140
	1A□5	4	160	40	200	205	166	134	130	-	55	140
112M	1B□2	2,6	190	45	226	225	193	145	152	-	64	140
		4	190	45	226	235	192	159	156	-	65	140
132S	1C□0 1C□1	2,4,6	216	50	256	268	218	177	160	354	69	140
		2	216	50	256	268	218	177	160	354	69	140
132M	1C□2 1C□3	4,6	216	50	256	268	218	177	160	354	69	178
		6	216	55	262	296	221.5	188.5	156	-	65	178
160M	1D□2 1D□3	2,4,6	254	60	314	324	260	208	225	426	94	210
		2	254	60	314	324	260	208	225	426	94	210
160L	1D□4	2,4	254	60	314	324	260	208	225	426	94	254
		6	254	65	314	314	252	211	218	-	82.5	254
180M 180L	1E□2 1E□4	2,4	279	65	339	368	275	223	231	472	94	241
		4,6	279	65	339	368	275	223	231	472	94	279
200L	2A□4 2A□5 2A□5	2,4,6	318	70	388	415	310	245	255	585	102	305
		2	318	70	378	410	305	250	288	540	107.5	305
		6	318	70	388	415	310	245	255	585	102	305
225S 225M	2B□0 2B□2	4	356	80	436	449	330	278	288	564	107.5	286
		2	356	80	436	449	330	278	288	564	107.5	311
		4,6										

¹⁾ 包含螺栓头的尺寸 Measured across the bolt heads. ²⁾ 该尺寸为 DIN EN 50347 标准所列机座号对应尺寸 This dimension is assigned in DIN EN 50347 to the frame size listed.

IM B5 以及 IM V1 安装方式 Type of construction IM B5 and IM V1

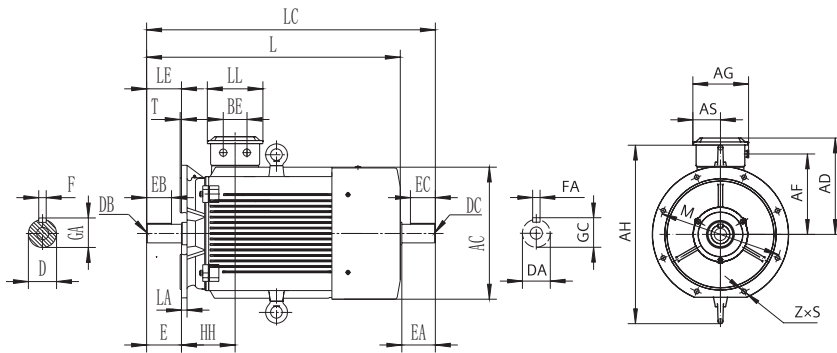

IM B14 安装结构型式 Type of construction IM B14

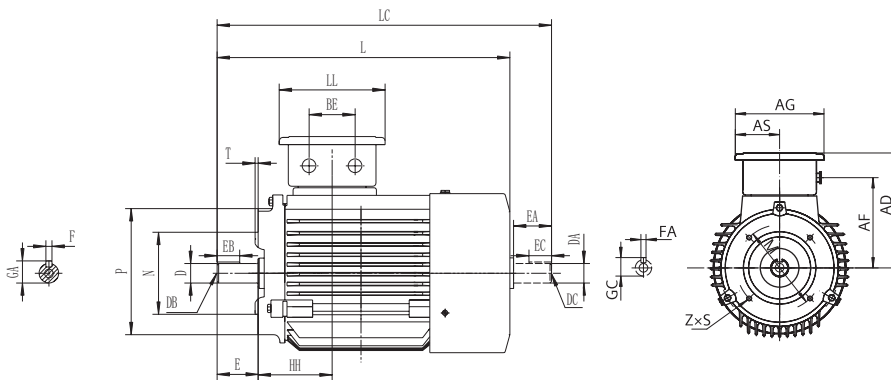

尺寸图依据 IEC 标准 Dimension designation according to IEC standards

驱动端轴伸直径 DE shaft extension

	BB	BC	BE	C	H	h	HA	HH	K / K'	L	LL	D	DB	E	EB	F	GA
	188	24	-	63	100	60	14	77	12	465	110	28	M10	60	40	8	31
	233	18	54	63	100	25.5	14	83/240 ³⁾	12	427	111	28	M10	60	50	8	31
	196	20	42	70	112	48	15	87	12	450	119	28	M10	60	40	8	31
	216	38	46	70	112	21	15	69/211 ³⁾	12	426	122	28	M10	60	50	8	31
	186	23	54	89	132	62	15	121.5	12	520	116	38	M12	80	70	10	41
	186	23	54	89	132	62	15	121.5	12	520	116	38	M12	80	70	10	41
	224	23	54	89	132	62	15	121.5	12	565	116	38	M12	80	70	10	41
	256	23	46	89	132	41	18	99/289 ³⁾	12	540	122	38	M12	80	70	10	41
	258	24	68	108	160	66	20	159	15	620	158	42	M16	110	100	12	45
	258	24	68	108	160	66	20	159	15	620	158	42	M16	110	100	12	45
	302	24	68	108	160	66	20	159	15	680	158	42	M16	110	100	12	45
	304	25	56	108	160	24.5	20	146/324 ³⁾	14.5	654	165	42	M16	110	100	12	45
	301	30	68	121	180	86	22	158	15	725	158	48	M16	110	100	14	51.5
	301	30	68	121	180	86	22	158	15	765	158	48	M16	110	100	14	51.5
	369	32	72	133	200	85	25	186	19	810	197	55	M20	110	80	16	59
	369	32	85	133	200	64.5	25	203	19	810	215	55	M20	110	100	16	59
	369	32	72	133	200	85	25	186	19	810	197	55	M20	110	80	16	59
	348	31	85	149	225	89.5	34	212	19	855	215	60	M20	140	125	18	64
	373	31	85	149	225	89.5	34	212	19	880	215	55	M16	110	100	16	59
										910		60	M20	140	125	18	64

³⁾ 该尺寸仅适用于接线盒位于左侧的电机 This dimension only suitable for terminal box on the left side.

外形尺寸 Dimension drawings

1TL0004 铸铁系列电机 Cast-iron series 1TL0004

机座号从 100L~355L Frame sizes 100L to 355L

IM B3 安装结构方式 Type of construction IM B3

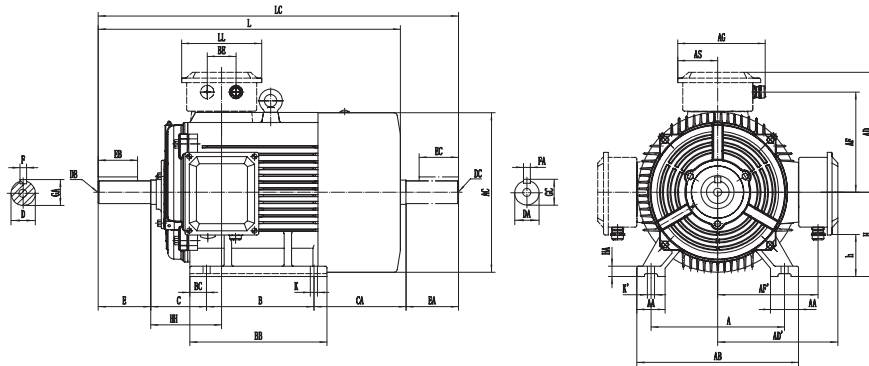

IM B35 安装结构方式 Type of construction IM B35

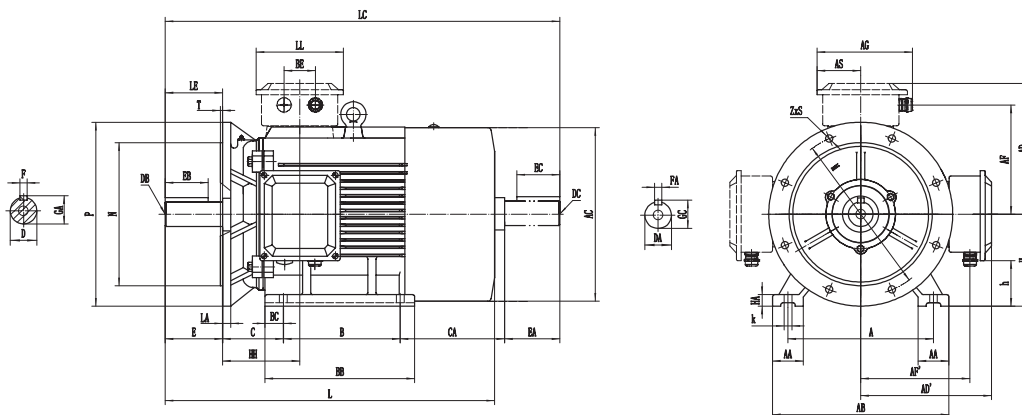

机座号 Frame size	类型 Type 1TL0004-	极数 Poles	尺寸图依据 IEC 标准 Dimension designation according to IEC standards										
			A	AA	AB	AC ¹⁾	AD / AD'	AF / AF'	AG	AH	AS	B ²⁾	
250M	2C□2	2 4,6	406	90	490	503	373	310.5	338	610	123	349	
280S	2D□0	2 4,6	457	85	542	544	390	317	285	710	119	368	
280M	2D□2	2 4,6	457	85	542	544	390	317	285	710	119	419	
315S	3A□0	2 4,6	508	120	628	596	505	410	380	810	160	406	
315M	3A□2	2 4,6	508	120	628	596	505	410	380	810	160	457	
315L	3A□5/3A□6/3A□7	2	508	120	610	622	570/430	488	423	898	199	508	
		4	508	120	628	596	505	410	380	810	160	508	
		6	508	120	628	596	505	410	380	810	160	508	
355M	3B□2	2	610	120	730	712	625	514	454	935	181	560	
		4,6	610	120	730	712	625	514	454	935	181	560	
	355L	3B□3	2	610	120	730	712	625	514	454	935	181	560
			4,6	610	120	730	712	625	514	454	935	181	560
		3B□4	6	610	120	730	712	625	514	454	935	181	560
			2	610	120	730	712	625	514	454	935	181	630
3B□5	4,6	610	120	730	712	625	514	454	935	181	630		
	2	610	120	730	712	625	514	454	935	181	630		

¹⁾ 包含螺栓头的尺寸 Measured across the bolt heads.

IM B5 以及 IM V1 安装方式 Type of construction IM B5 and IM V1

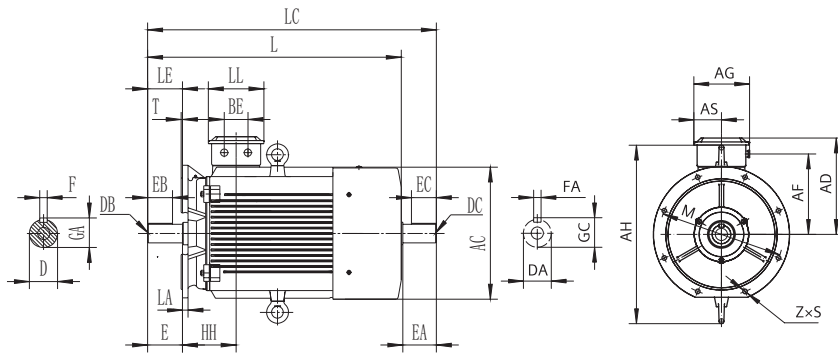

尺寸图依据 IEC 标准 Dimension designation according to IEC standards

驱动端轴伸直径 DE shaft extension

	BB	BC	BE	C	H	h	HA	HH	K / K'	L	LL	D	DB	E	EB	F	GA
	421	36	84	168	250	81	22	260	24	965	246	60 65	M20	140	125	18	64 69
	485	74	80	190	280	150	35	218.5	24	975	224	65 75	M20	140	100	18 20	69 79.5
	537.5	74	80	190	280	150	35	218.5	24	1025	224	65 75	M20	140	100	18 20	69 79.5
	577	60	110	216	315	120	45	257	28	1205	310	65	M20	140	100	18	69
	516			216						1145		80		170	130	22	85
	577	60	110	216	315	120	45	257	28	1205	310	65	M20	140	100	18	69
										1235		80		170	130	22	85
	770	70	140	216	315	675	50	382	28	1475	380	65	M20	140	125	18	69
										1505		80		170	140	22	85
	628	60	110	216	315	120	45	257	28	1355	310	80	M20	170	130	22	85
	696	68	125	254	355	136	53	281	28	1370	362	75	M20	140	100	20	79.5
										1400		95	M24	170	130	25	100
	696	68	125	254	355	136	53	281	28	1370	362	75	M20	140	100	20	79.5
										1400		95	M24	170	130	25	100
	696	68	125	254	355	136	53	281	28	1400	362	95	M24	170	130	25	100
	750	68	125	254	355	136	53	281	28	1490	362	75	M20	140	100	20	79.5
										1520		95	M24	170	130	25	100
	750	68	125	254	355	136	53	281	28	1490	362	75	M20	140	100	20	79.5
										1520		95	M24	170	130	25	100

²⁾ 该尺寸为 DIN EN 50347 标准所列机座号对应尺寸 This dimension is assigned in DIN EN 50347 to the frame size listed.

外形尺寸 Dimension drawings

法兰尺寸 Flange dimension

IM B5、IM B35、IM V1、IM V3 安装结构型式 Type of construction IM B5, IM B35, IM V1, IM V3

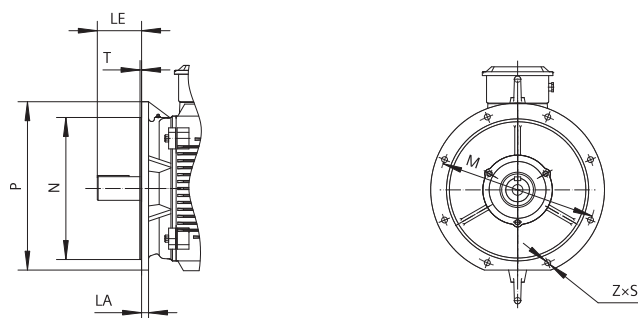

机座号 Frame size	安装结构形式 Type of construction	法兰带通孔 (FF/A) / 法兰带内螺纹孔 (FT/C) Flange with through holes (FF/A) / tapped holes (FT/C)
		按 DIN / EN 50 347 标准 According to DIN EN 50347
100	IM B5, IM B35, IMV1, IM V3	FF 215
	IM B14, IM V18, IM V19	FT 130
112	IM B5, IM B35, IMV1, IM V3	FF 215
	IM B14, IM V18, IM V19	FT 130
132	IM B5, IM B35, IMV1, IM V3	FF 265
160	IM B5, IM B35, IMV1, IM V3	FF 300
180	IM B5, IM B35, IMV1, IM V3	FF 300
200	IM B5, IM B35, IMV1, IM V3	FF 350
225	IM B5, IM B35, IMV1, IM V3	FF 400
250	IM B5, IM B35, IMV1, IM V3	FF 500
280	IM B5, IM B35, IMV1, IM V3	FF 500
315	IM B5, IM B35, IMV1, IM V3	FF 600
355	IM B5, IM B35, IMV1, IM V3	FF 740

法兰尺寸 Flange dimension

IM B14、IM V18、IM V19 安装结构型式 Type of construction IM B14, IM V18, IM V19

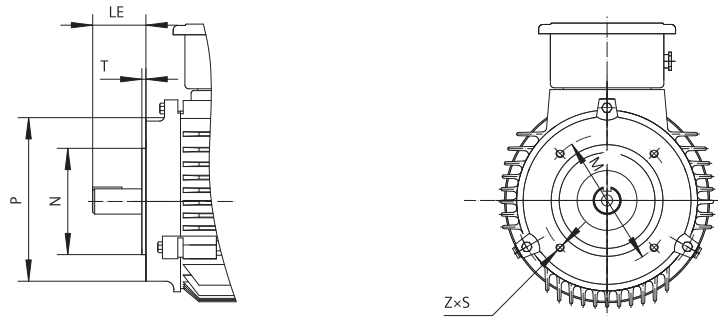

尺寸图依据 Dimension designation according to IEC standards

	LA	LE	M	N	P	S	T	Z
13		60	215	180	250	14.5	4	4
—		60	130	110	160	M 8	3.5	4
14		60	215	180	250	14.5	4	4
—		60	130	110	160	M 8	3.5	4
14		80	265	230	300	14.5	4	4
14		110	300	250	350	18.5	5	4
15		110	300	250	350	18.5	5	4
17		110	350	300	400	18.5	5	4
20		110 / 140	400	350	450	18.5	5	8
22		140	500	450	550	18.5	5	8
22		140	500	450	550	18.5	5	8
22		140 / 170	600	550	660	24	6	8
25		140 / 170	740	680	800	24	6	8

西门子电机（中国）有限公司

地址：江苏省仪征市汽车工业园众鑫路 99 号

电话：+86 514 85718108

传真：+86 514 85718083

邮编：211400

邮箱：beide-motor.ssml@siemens.com

网址：www.beide-motor.cn

774-SH902774-03182

西门子电机（中国）有限公司版权所有
如有改动 恕不事先通知。

Siemens Standard Motors Ltd.

Address: No.99,Zhongxin Road, Yizheng City, Jiangsu Province
211400,P.R.China

Tel: +86 514 85718108

Fax: +86 514 85718083

Post code: 211400

E-Mail: beide-motor.ssml@siemens.com

Web site: www.beide-motor.cn