



1MT0013 系列粉尘防爆低压三相异步电动机
1MT0013 series Dust Explosion-proof Low Voltage
Three-phase Asynchronous Motor

产品样本 Catalogue
2022. 06



公司概况 Company Profile

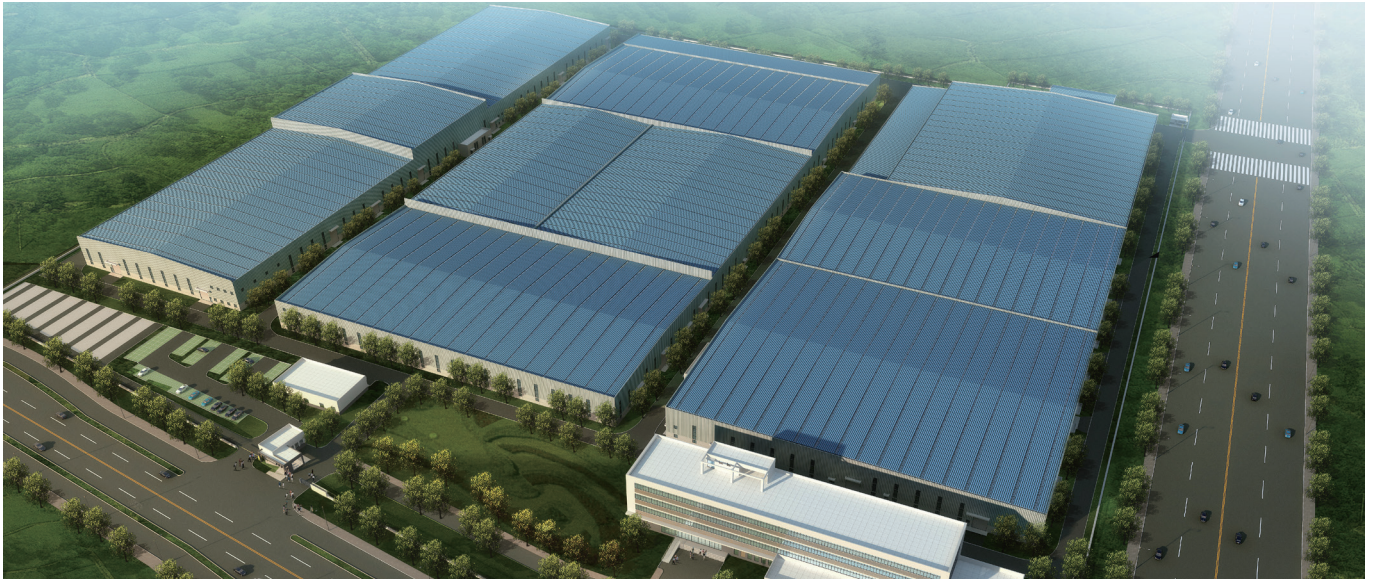

西门子电机（中国）有限公司 Siemens Standard Motors Ltd. (SSML)

西门子电机（中国）有限公司是西门子在中国的独资企业，位于江苏省仪征市，公司主要致力于研发和生产中小型低压三相异步电动机。目前生产符合 IEC 标准的西门子品牌三相异步电动机、以及按中国标准设计的贝得品牌系列三相异步电动机。

作为西门子在全球中小型低压电机产品的重要生产基地之一，公司坚持秉承西门子 100 多年的电动机设计和生产经验和先进技术，拥有先进的生产设备和生产工艺，采用西门子特色的现代化管理模式，严格按照国际标准 ISO9001:2015 实施全面质量管理，竭诚为广大客户提供优质的产品和服务！

Siemens Standard Motors Ltd. (SSML) is a Siemens-owned company in China. SSML is located in Yizheng City, Jiangsu Province. The company focuses on developing and producing small and medium low-voltage motors. Currently, SSML mainly produce Siemens brand low voltage AC motors according to IEC standards, and Beide brand low voltage motors designed according to China local standards.

As one of Siemens main low-voltage motor production facilities worldwide, SSML uses the knowledge and experience of more than 100 years in motor design and manufacturing, owns the advanced manufacture equipment and process, adopts the SIEMENS modern management model, and implements comprehensive quality control according to ISO9001 2015. SSML will continuously serve customers with high quality products and good service.

公司概况 Company Profile



质量方针

- 质量从我做起，第一次把事情做对。
- 鼓励员工发现问题并勇于承担责任。
- 拒不接受不合格产品。
- 持续改进我们的流程，超越客户期望。

Quality Guideline

- Quality starts with me, Do it right in the first time.
- Encourage our employee to address problem openly and take responsibility.
- Refuse to accept defective product.
- Continuously improve our process to exceed customer's expectation.

环境方针

西门子电机（中国）有限公司的环境、职业健康和安全管理方针是：

- 我们依据 ISO14001:2015 和 ISO 45001-2018 标准的要求，有效建立、实施环境和职业健康安全管理体系，不断提高，持续改进。
- 我们承诺遵守环境、职业健康安全相关的法律法规，履行环境保护及职业健康安全防护职责。
- 我们致力于履行应负的社会责任和义务，合理使用资源，保护环境，加强职业健康安全管理，实现安全生产零伤害。

Environmental Guideline

EHS Policy of Siemens Standard Motors Ltd. is as follows:

- We institute and implement a continuously improving management system addressing our environment, occupational health and safety in compliance with the requirements of ISO14001:2015 and ISO 45001-2018 criteria.
- We commit ourselves to abiding by the environmental, occupational health and safety laws and regulations, and fulfilling our duties in environmental protecting and occupational health safeguarding.
- We commit ourselves to the fulfillment of our social responsibility and obligation, properly harnessing resources, protecting our environment, enhancing occupational health and safety management with the ultimate goal of zero harm in our production process.

目录 Contents

防爆简介 Explosion-proof Profile	5
概述 Overview	9
MLFB 介绍 Order No.	15
选型技术数据表 Technical data table	16
选件 Options	20
外形尺寸 Dimension drawings	22
证书 Certificates	29



防爆简介 Explosion-proof Profile

区域的分类 Classification of zones

有爆炸风险的场所被划分为不同的区域。划分区域的标准取决于危险物质存在的时间以及发生危险的概率。各个区域分类的信息和规则遵循以下标准：

- GB 3836.14, IEC/EN 60079-10-1 适用于气体环境
- GB 12476.3, IEC/EN 60079-10-2 适用于粉尘环境

此外，在不同的爆炸分组和温度等级之间进行了分类，这些都包含在危险等级评估中。

Areas subject to explosion hazard are divided into zones. Zoning is based on the presence time of explosive substances and probability of explosion. Information and specifications for classification of the zones are laid down in the following standards:

- GB 3836.14, IEC/EN 60079-10-1 for gas atmospheres
- GB 12476.3, IEC/EN 60079-10-2 for dust atmospheres

Furthermore, a distinction is made between various explosion groups as well as temperature classes and these are included in the hazard assessment.

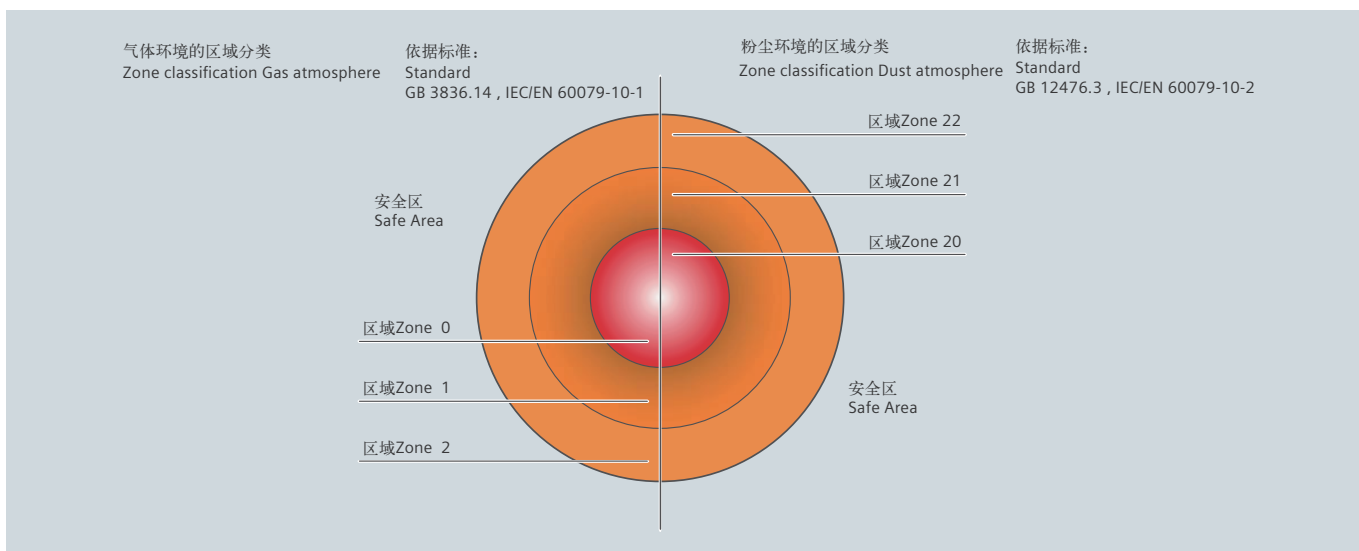

根据各区域的分类和存在的危险，所使用的设备必须满足最低防护要求。设备必须在符合要求的工况下使用，以避免点燃外部的爆炸性环境。

Depending on the particular zone and therefore the associated hazard, operating equipment must comply with defined minimum requirements regarding the type of protection. The different types of protection require corresponding measures to prevent ignition that should be implemented at the motor in order to prevent a surrounding explosive atmosphere from being ignited.

区域 Zone		区域定义的标准: Zone definition acc. to GB3836.14 & IEC/EN 60079-10-1 用于气体环境 for gas atmospheres GB 12476.3 & IEC/EN 60079-10-2 用于粉尘环境 for dust atmospheres	分配 保护类型 Assigned types of protection	分类根据 Category according to 2014/34/EU	设备保护等级根据 Equipment protection level acc. to GB3836.1 & IEC/EN 60079-0
气体 Gas 1) 2)	粉尘 Dust 1) 2)				
0	-	持续、长时间或频繁存在爆炸性气体环境的区域 An area in which there is an explosive gas atmosphere constantly, over a long period or frequently.	不允许低压电机 Low-voltage motors not permitted	1	Ga
1	-	在正常运行过程中, 预计偶尔会出现爆炸性气体环境的 An area in which it is expected that an explosive gas atmosphere will occur occasionally during normal operation.	Ex e(GB) 或 Ex eb(IEC), Ex de, Ex d(GB) 或 Ex db(IEC)	2	Gb
2	-	在正常运行过程中, 预计很少或只短暂出现爆炸性气体环境的区域 An area in which it is expected that an explosive gas atmosphere will occur only rarely and then only briefly during normal operation.	Ex nA(GB) 或 Ex ec(IEC)	3	Gc
-	20	持续、长时间或频繁存在由粉尘-空气混合物组成的爆炸性气体环境的区域 An area in which there is an explosive gas atmosphere comprising a dust-air mixture constantly, over a long period or frequently.	不允许低压电机 Low-voltage motors not permitted	1	Da
-	21	在正常运行的过程中, 预计会偶尔存在由粉尘-空气混合物组成的爆炸性气体环境的区域 An area in which it is expected that an explosive gas atmosphere comprising a dust-air mixture will occur occasionally during normal operation.	Ex tb	2	Db
-	22	在正常运行的过程中, 预计很少或只短暂在空气中形成一团易燃尘埃的爆炸性气体环境的区域 An area in which it is expected that an explosive gas atmosphere in the form of a cloud of flammable dust in air will occur only rarely and then only briefly during normal operation.	Ex tc ³⁾	3	Dc

¹⁾ 电机用于

- 区域 1 也可以用于区域 2.
- 区域 21 也可以用于区域 22.

²⁾ 若电机仅有气体防爆认证或粉尘防爆认证, 不允许在混合环境中使用。混合环境: 爆炸性的气体和粉尘同时在大气环境中存在。

³⁾ Ex tc 电机不允许在含有导电粉尘的环境中运行。

¹⁾ Motors of

- Zone 1 can also be used in Zone 2.
- Zone 21 can also be used in Zone 22.

²⁾ Motors which are certified for gas or dust protection must not be used in hybrid mixtures! Hybrid mixtures: when explosive gas and dust atmospheres occur simultaneously.

³⁾ Ex tc motors are not approved for operation in environments containing conductive dust.

应用 Application

以下情况常常需要选用防爆电机, 以防止爆炸对人造成严重伤害和对财产造成严重损失。

- 化工和石化行业
- 矿物油和天然气生产
- 煤气产业
- 煤气供应公司
- 加油站
- 焦化厂
- 磨粉厂(例如: 玉米, 固体)
- 污水处理厂
- 木材加工(例如: 木屑, 树脂)
- 其他易受爆炸危害的行业

The explosion-proof motors are often used in the following industries to prevent explosion hazards that result in serious injury to persons and severe damage to property.

- Chemical and petrochemical industry
- Production of mineral oil and gas
- Gas works
- Gas supply companies
- Petrol stations
- Coking plants
- Mills (e.g. corn, solids)
- Sewage treatment plants
- Wood processing (e.g. sawdust, tree resin)
- Other industries subject to explosion hazards

常见可燃性粉尘特性

Characteristics of common flammable dust

粉尘种类 Type of dust	粉尘名称 Type of dust	高温表面堆积粉尘层 (5mm) 的引燃温度 (°C) Ignition temperature of dust layer (5mm) at high temperature surface (5mm) (°C)	粉尘云的引 燃温度 (°C) Ignition temperature of dust cloud (°C)	爆炸下限 浓度 (g/m ³) Lowest concentration of explosion (g/m ³)	粉尘平均 粒径 (μm) Average particle size of dust (μm)	危险 性质 Dangerous nature	粉尘 等级 Dust grade
金属 Metal	铝 (表面处理) Aluminum (surface treatment)	320	590	37~50	10~15	导 CONDUCTIVE	III C
	铝 (含脂) Aluminum (containing fat)	230	400	37~50	10~20	导 CONDUCTIVE	III C
	铁 Iron	240	430	153~204	100~150	导 CONDUCTIVE	III C
	镁 magnesium	340	470	44~59	5~10	导 CONDUCTIVE	III C
	红磷 Phosphorus	305	360	48~64	30~50	非 NON-CONDUCTIVE	III B
	炭黑 Carbon	535	> 600	36~45	10~20	导 CONDUCTIVE	III C
	钛 Titanium	290	375	-	-		III C
	锌 Zinc	430	530	212~284	10~15	导 CONDUCTIVE	III C
	电石 Calcium carbide	325	555	-	<200	非 NON-CONDUCTIVE	III B
	钙硅铝合金 (8% 钙, 30% 硅, 55% 铝) Calcium silicon aluminum alloy (8% calcium, 30% silicon, 55% aluminum)	290	465	-	-	导 CONDUCTIVE	III C
	硅铁合金 (45% 硅) Ferrosilicon alloy (45% silicon)	> 450	640	-	-	导 CONDUCTIVE	III C
	黄铁矿 Pyrite	445	555	-	<90	导 CONDUCTIVE	III C
锆石 Zircon	305	360	92~123	5~10	导 CONDUCTIVE	III C	
化学 药品 Chemical medicine	硬脂酸锌 Zinc stearate	熔融 Melting	315	-	8~15	非 NON-CONDUCTIVE	III B
	萘 Naphthalene	熔融 Melting	575	28~38	30~100	非 NON-CONDUCTIVE	III B
	蒽 Anthracene	熔融升华 Melting sublimation	505	29~39	40~50	非 NON-CONDUCTIVE	III B
	己二酸 Adipic acid	熔融 Melting	580	65~90	-	非 NON-CONDUCTIVE	III B
	苯二 (甲) 酸 Benzene 2 (a) acid	熔融 Melting	650	61~83	80~100	非 NON-CONDUCTIVE	III B
	无水苯二 (甲) 酸 (粗制品) Anhydrous benzene 2 (a) acid (crude)	熔融 Melting	605	52~71	-	非 NON-CONDUCTIVE	III B
	苯二甲酸酐 Benzoate	熔融 Melting	> 700	37~50	-	非 NON-CONDUCTIVE	III B
	无水马来酸 (粗制品) Anhydrous maleic acid (crude)	熔融 Melting	500	82~113	-	非 NON-CONDUCTIVE	III B
	醋酸钠酯 Sodium acetate	熔融 Melting	520	51~70	5~8	非 NON-CONDUCTIVE	III B
	结晶紫 Crystal violet	熔融 Melting	475	46~70	15~30	非 NON-CONDUCTIVE	III B
	四硝基咪唑 Four nitro carbazole	熔融 Melting	395	92~123	-	非 NON-CONDUCTIVE	III B
	二硝基甲酚 Two nitro cresol	熔融 Melting	340	-	40~60	非 NON-CONDUCTIVE	III B
	阿司匹林 Aspirin	熔融 Melting	405	31~41	60	非 NON-CONDUCTIVE	III B
	肥皂粉 Soap powder	熔融 Melting	575	-	80~100	非 NON-CONDUCTIVE	III B
	青色燃料 Green fuel	350	465	-	300~500	非 NON-CONDUCTIVE	III B
萘酚燃料 Naphthol fuel	395	415	133~184	-	非 NON-CONDUCTIVE	III B	
合成 树脂 Synthetic resin	聚乙烯 Polyethylene	熔融 Melting	410	26~35	30~50	非 NON-CONDUCTIVE	III B
	聚丙烯 Polypropylene	熔融 Melting	430	25~35	-	非 NON-CONDUCTIVE	III B
	聚苯乙烯 Polystyrene	熔融 Melting	475	27~37	40~60	非 NON-CONDUCTIVE	III B
	苯乙烯 (70%) 与丁二烯 (30%) 粉状聚合物 Styrene (70%) and butadiene (30%) powdery polymerization	熔融 Melting	420	27~37	-	非 NON-CONDUCTIVE	III B
	聚乙烯醇 Polyvinyl alcohol	熔融 Melting	450	42~55	5~10	非 NON-CONDUCTIVE	III B
	聚丙烯腈 Polyacrylonitrile	熔融炭化 Melting carbonization	505	35~55	5~7	非 NON-CONDUCTIVE	III B
	聚氨酯 (类) Polyurethane (class)	熔融 Melting	425	46~63	50~100	非 NON-CONDUCTIVE	III B
	聚乙烯四肽 Polythene four peptide	熔融 Melting	480	52~71	<200	非 NON-CONDUCTIVE	III B
	聚乙烯氮戊环酮 Polyvinyl amyl ketone	熔融 Melting	465	42~58	10~15	非 NON-CONDUCTIVE	III B
	聚氯乙烯 Polyvinyl chloride (PVC)	熔融炭化 Melting carbonization	595	63~86	4~5	非 NON-CONDUCTIVE	III B
	氯乙烯 (70%) 与苯乙烯 (30%) 粉状聚合物 Chloroethylene (70%) and styrene (30%) powdery polymerization	熔融炭化 Melting carbonization	520	44~60	30~40	非 NON-CONDUCTIVE	III B
	酚醛树脂 (酚醛清漆) Phenolic resin (phenolic varnish)	熔融炭化 Melting carbonization	520	36~40	10~20	非 NON-CONDUCTIVE	III B
有机玻璃粉 Organic glass powder	熔融炭化 Melting carbonization	485	-	-	非 NON-CONDUCTIVE	III B	

粉尘种类 Type of dust	粉尘名称 Type of dust	高温表面堆积粉尘层 (5mm) 的引燃温度 (°C) Ignition temperature of dust layer (5mm) at high temperature surface (5mm) (°C)	粉尘云的引 燃温度 (°C) Ignition temperature of dust cloud (°C)	爆炸下限 浓度 (g/m ³) Lowest concentration of explosion (g/m ³)	粉尘平均 粒径 (μm) Average particle size of dust (μm)	危险 性质 Dangerous nature	粉尘 等级 Dust grade
天然 树脂 Natural resin	骨胶 (虫胶) Bone glue (shellac)	沸腾 Boiling	475	-	20~50	非 NON-CONDUCTIVE	III B
	硬质橡胶 Hard rubber	沸腾 Boiling	360	36~49	20~30	非 NON-CONDUCTIVE	III B
	软质橡胶 Soft rubber	沸腾 Boiling	425	-	80~100	非 NON-CONDUCTIVE	III B
	天然树脂 Natural resin	熔融 Melting	370	38~52	20~30	非 NON-CONDUCTIVE	III B
	葜钯树脂 Mantis palladium resin	熔融 Melting	330	30~41	20~50	非 NON-CONDUCTIVE	III B
沥青 蜡类 Asphalt waxes	松香 Rosin	熔融 Melting	325	-	50~80	非 NON-CONDUCTIVE	III B
	硬蜡 Hard wax	熔融 Melting	400	26~36	80~50	非 NON-CONDUCTIVE	III B
	绕组沥青 Winding asphalt	熔融 Melting	620	-	50~80	非 NON-CONDUCTIVE	III B
	硬沥青 Hard asphalt	熔融 Melting	620	-	50~150	非 NON-CONDUCTIVE	III B
农产品 Agricultural products	烧焦油沥青 Charred asphalt	熔融 Melting	580	-	-	非 NON-CONDUCTIVE	III B
	裸麦粉 Rye flour	325	415	67~93	30~50	非 NON-CONDUCTIVE	III B
	裸麦谷物粉 (未处理) Rye grain flour (untreated)	305	430	-	50~100	非 NON-CONDUCTIVE	III B
	裸麦筛落粉 (粉碎品) Rye powder (crushed)	305	415	-	30~40	非 NON-CONDUCTIVE	III B
	小麦粉 Wheat flour	炭化 Carbonization	410	-	20~40	非 NON-CONDUCTIVE	III B
	小麦谷物粉 Wheat grain powder	290	420	-	15~30	非 NON-CONDUCTIVE	III B
	小麦筛落粉 (粉碎品) Wheat sifting powder (comminuted product)	290	410	-	3~5	非 NON-CONDUCTIVE	III B
	乌麦、大麦、谷物粉 Rye, barley and cereal flour	270	440	-	50~150	非 NON-CONDUCTIVE	III B
	筛米糠 Sieve rice bran	270	420	-	50~150	非 NON-CONDUCTIVE	III B
	玉米淀粉 Corn starch	炭化 Carbonization	410	-	2~30	非 NON-CONDUCTIVE	III B
	马铃薯粉 Potato powder	炭化 Carbonization	430	-	60~80	非 NON-CONDUCTIVE	III B
	布丁粉 Pudding powder	炭化 Carbonization	395	-	10~20	非 NON-CONDUCTIVE	III B
	糊精粉 Dextrin powder	400	400	71~99	20~30	非 NON-CONDUCTIVE	III B
	砂糖粉 Sugar powder	熔融 Melting	360	77~107	20~40	非 NON-CONDUCTIVE	III B
	乳糖 lactose	熔融 Melting	450	83~115	-	非 NON-CONDUCTIVE	III B
纤维 鱼粉 Fiber fish meal	可可子粉 (脱脂品) Cocoa seed powder (nonfat)	245	460	-	30~40	非 NON-CONDUCTIVE	III B
	咖啡粉 (精致品) Coffee powder (delicacy)	收缩	600	-	40~80	非 NON-CONDUCTIVE	III B
	啤酒麦芽粉 Beer malt powder	285	405	-	100~500	非 NON-CONDUCTIVE	III B
	紫苜蓿 Purple alfalfa	280	480	-	200~500	非 NON-CONDUCTIVE	III B
	亚麻粕粉 Flax meal powder	285	470	-	-	非 NON-CONDUCTIVE	III B
	菜种渣粉 Dish of slag powder	炭化	465	-	400~500	非 NON-CONDUCTIVE	III B
	鱼粉 Fish meal	炭化	485	-	80~100	非 NON-CONDUCTIVE	III B
	烟草纤维 Tobacco fiber	290	485	-	50~100	非 NON-CONDUCTIVE	III A
	木棉纤维 Kapok fiber	385	-	-	-	非 NON-CONDUCTIVE	III A
	人造短纤维 Artificial short fiber	305	-	-	-	非 NON-CONDUCTIVE	III A
	亚硫酸盐纤维 Sulfite fiber	380	-	-	-	非 NON-CONDUCTIVE	III A
	木质纤维 Wood fiber	250	445	-	40~80	非 NON-CONDUCTIVE	III A
	纸纤维 Paper fiber	360	-	-	-	非 NON-CONDUCTIVE	III A
	椰子粉 Coconut powder	280	450	-	100~200	非 NON-CONDUCTIVE	III B
	软木粉 Cork powder	325	460	44~59	30~40	非 NON-CONDUCTIVE	III B
针叶树 (松) 粉 Coniferous tree (pine) powder	325	440	-	70~150	非 NON-CONDUCTIVE	III B	
硬木 (丁钠橡胶) 粉 Hard wood (sodium rubber) powder	315	420	-	70~100	非 NON-CONDUCTIVE	III B	
燃料 Fuel	泥煤粉 (堆积) Coal dust (packing)	260	450	-	60~90	导 CONDUCTIVE	III C
	褐粉煤 (生褐粉) Lignite (raw brown powder)	260	450	49~68	2~3	非 NON-CONDUCTIVE	III B
	褐煤粉 Brown pulverized coal	230	185	-	3~7	导 CONDUCTIVE	III C
	无烟煤粉 Smoke pulverized coal	235	595	41~57	5~11	导 CONDUCTIVE	III C
	瓦斯煤粉 Pulverized coal gas	225	580	35~48	5~10	导 CONDUCTIVE	III C
	焦炭用煤粉 Pulverized coal for coke	280	610	33~45	5~10	导 CONDUCTIVE	III C
	贫煤粉 Coal powder	285	680	34~45	5~7	导 CONDUCTIVE	III C
	无烟煤粉 Smokeless pulverized coal	> 430	> 600	-	100~130	导 CONDUCTIVE	III C
	木炭粉 (硬质) Charcoal powder (hard)	340	595	39~52	1~2	导 CONDUCTIVE	III C
	泥煤焦炭粉 Peat coke powder	360	615	40~54	1~2	导 CONDUCTIVE	III C
	褐煤焦炭粉 Lignite coke powder	235	-	-	4~5	导 CONDUCTIVE	III C
煤焦炭粉 Coal coke powder	430	> 750	37~50	4~5	导 CONDUCTIVE	III C	

注:

- III A 级为可燃性飞絮;
- III B 级为非导电性粉尘;
- III C 级为导电性粉尘。

Note:

- III A grade is Combustible flyings;
- III B grade is non-conductive dust;
- III C grade is conductive dust.

概述 Overview



额定功率：0.55 ~ 315 kW

机座号：80 ~ 355

电压与频率：支持多种电压与频率

冷却方式：IC411

防爆标志：Ex tD A21 IP65 T130℃

防护等级：IP65

绝缘系统：F级

注油装置：机座号280及以上电机标配

环境温度：-15℃ ~ +40℃

海拔高度：不超过1000米

Rated output: 0.55 ~ 315 kW

Frame size: 80 ~ 355

Voltage and Frequency: Support multiple voltage and frequency

Cooling method: IC411

Frame-proof marking: Ex tD A21 IP65 T130℃

Protect degree: IP65

Insulation class: F

Re-greasing device: FS280 and above motor as standard

Ambient temperature: -15℃ ~ +40℃

Site altitude above sea level: Not exceed 1000m

贝得系列高效粉尘防爆型三相异步电动机是全封闭、自扇冷高效电动机，该系列产品效率满足 GB18613-2020 能效等级 3 级标准要求。该系列产品引用西门子设计技术，具有性能优良，使用安全可靠，振动小、噪声低等特点，并且符合环保要求；其生产设备采用先进的数控机床设备、引用西门子先进的绝缘结构设计以及制造工艺，采用优质的冷轧硅钢片以及经过严格质量检测与控制的高品质轴承。

贝得粉尘防爆电机可用于粮食或饲料加工、木材加工、面粉加工或储存，以及金属、化学药品、合成树脂、农产品、各种纤维、燃料等等可燃性粉尘场所。具体粉尘种类见“粉尘特性举例”，但该电机不适用于瓦斯和/或可燃性粉尘引起危险的煤矿井下以及煤矿地面装置用电气设备，也不适用于不需要大气中的氧即可燃烧的炸药粉尘或自燃物质（如磷粉）。

贝得粉尘防爆电动机防爆性能符合 GB 12476.1-2013 《可燃性粉尘环境用电气设备 第1部分：通用要求》和 GB 12476.5-2013 《可燃性粉尘环境用电气设备 第5部分：外壳保护型“tD”》的规定，适用爆炸性粉尘环境的 21 区，22 区。

Beide series high efficiency dust explosion-proof three-phase asynchronous motor is totally enclosed, self-fan cooled high efficiency motor. The products meet the requirements of the GB18613-2020 efficiency of energy efficiency grade 3. The series products introduce Siemens design technology with excellent performance, safe and reliable to use, low vibration, low noise, and meet environmental protection requirements. Its production equipments adopt advanced CNC machine tool equipment, citing Siemens advanced insulation structure design and manufacturing process, use high quality cold rolled silicon steel sheet and high quality bearing with strict quality control.

Beide dust explosion-proof motor can be used for food or forage machine, wood machine, flour machine or storage, as well metal, chemicals, synthetic resin, agricultural products and all kinds of combustible dust places such as fiber, fuel and so on. Detailed types of dust refer to "dust characteristics example," but this series motors are not suitable for gas or underground coal mine with combustible dust and coal mine ground device with electrical equipment, also can't be used in place with explosive dust and spontaneous combustion substances (e.g. phosphorus powder) but can burn without oxygen from the atmosphere.

Beide dust explosion-proof motor's performance fulfill GB 12476.1-2013 "Combustible dust environment for electrical equipment -part 1: General requirements" and GB 12476.5-2013 "Combustible dust environment for electrical equipment - Part 5: Housing protection type" tD "", suitable for explosive dust environment Zone 21 or zone 22.

噪声 Noise levels

噪声值

噪声值根据 DIN EN ISO 1680 标准在噪音室测得。表面声压级噪声 L_{pfa} 计算表示单位为 dB (A)。声压级噪声的空间平均值是在其测量面上测得的。测量面是距离电机1米的测量包络面。声功率级噪声用 L_{WA} 来表示，单位为 dB (A)。噪音值见选型数据表，选型数据表中的噪声值仅适用于全封闭自扇冷却（冷却方式：IC411）。电动机在 50 Hz 电源供电空载运行时，噪音容差为 +3 dB。当在 60 Hz 电源下空载运行时，噪音容差大约为 +4 dB。

Noise levels for mains-fed operation

The noise levels are measured in accordance with DIN EN ISO 1680 in a anechoic room. It is specified as the A-valued measuring-surface sound pressure level L_{pfa} in dB (A). This is the spatial mean value of the sound pressure levels measured on the measuring surface. The measuring surface is a cube 1 m away from the motor surface. The sound power level is also specified as L_{WA} in dB (A). Please find the noise value in technical data table, the specified values are only valid for totally enclosed fan cooling (cooling method: IC411) motor with no load at 50 Hz with no load, and the tolerance is +3 dB. While motor operating 60 Hz with no load, the values are approximately +4 dB (A) higher.

振动 Vibration

所有电动机转子都使用半键按照 A 级（标准）振动等级进行动态平衡。电动机在空载时测得振动速度有效值不超过下表中的 A 级所列值。电机还可选择 B 级振动等级设计。

The rotors are dynamically balanced to severity grade A using a half key. Table below contains the effective vibration values for unloaded motors. Vibration grade B can be provided as option.

振动等级 Vibration Grade	机座号 Frame size (mm) 安装方式 Mounting	56 ≤ FS ≤ 132		H > 132	
		位移 Vibration displacement/μm	速度 Vibration velocity/(mm/s)	位移 Vibration displacement/μm	速度 Vibration velocity/(mm/s)
A	自由悬置 Free suspension	45	2.8	45	2.8
	刚性安装 Rigid mounting	-	-	37	2.3 2.8 ¹⁾
B	自由悬置 Free suspension	18	1.1	29	1.8
	刚性安装 Rigid mounting	-	-	24	1.5 1.8 ¹⁾

注：

¹⁾ 该值为 GB/T 10068-2020 中定义的轴中心高 H > 132mm 的两极电机，当两倍电网频率占主导时的振动速度限值。

Note:

¹⁾ The level are vibration velocity limit when the twice line frequency vibration level is dominant defined by GB/T 10068-2020, for 2p motors that frame size bigger than 132mm.

















铭牌示例 Nameplate

 贝得® DUST EXPLOSION PROOF THREE-PHASE ASYNCHRONOUS MOTOR 粉尘防爆型三相异步电动机		 Ex		
型号 TYPE	1MT0013-3AB5	3-3AA4-Z	LMH-2107/800003888993/003	Q/321081 KJA016-2021
160 kW	315L	380VΔ/660VY	COSφ0.87	290/168 A
EFF. 95.8 %	IM B3	Th.Cl. 155(F)	50 Hz	1485 r/min
驱动端轴承: 6319 C3	非驱动端轴承: 6319 C3		CNEx19.4902X	
润滑脂: 2# Li grease	润滑周期: 5000h	Ex tD A21 IP65 T130°C		
油脂量: 40g	GB18613-2020 Eff. -Grade3			
西门子电机(中国)有限公司 Siemens Standard Motors Ltd.				

防爆标志 Ex-Mark

Ex	tD	A21	IP65	T130°C
防爆标识 Marking for prevention of explosions				
防爆类型 Protection type: tD = 外壳保护型 Protection by enclosures				
设备类别 Equipment grouping: A型设备, 适用于21区 Group A, suitable for Zone 21				
外壳防护等级 (IP代码) Enclosure protection level (IP code)				
最高表面温度 Maximum surface temperature				

安装结构型式 Construction and mounting type

结构型式 Construction type	机座带底脚, 端盖无法兰 With feet and without flange on the end-shield (DE)					
安装型式 Mounting type	IM B3 FS 80 ~ 355	IM B6 FS 80 ~ 160	IM B7 FS80 ~ 160	IM B8 FS 80 ~ 160	IM V5 ¹⁾ FS 80 ~ 160	IM V6 ²⁾ FS 80 ~ 160
示意图 Diagram						
电动机订货号第 14 位号上 对应的字母 Letter, position 14 th of Motor code	A	T	U	V	C	D
结构型式 Construction type	机座不带底脚, 端盖有法兰 Without feet and with flange on the end-shield (DE)			机座带底脚, 端盖有法兰 With feet and with flange on the end-shield (DE)		
安装型式 Mounting type	IM B5 FS 80 ~ 280	IM V1 ¹⁾ FS 80 ~ 355	IM V3 ²⁾ FS 80 ~ 160	IM B35 FS 80 ~ 355	IM V15 ¹⁾ FS 80 ~ 160	IM V35 ²⁾ FS 80 ~ 160
示意图 Diagram						
电动机订货号第 14 位号上 对应的字母 Letter, position 14 th of Motor code	F	G	H	J	W	Y
结构型式 Construction type	机座不带底脚, 端盖有标准小法兰 Without feet and with C-flange on the end-shield (DE)			机座带底脚, 端盖有标准小法兰 With feet and with C-flange on the end-shield (DE)		
安装型式 Mounting type	IM B14 FS 80 ~ 160	IM V18 ¹⁾ FS 80 ~ 160	IM V19 ²⁾ FS 80 ~ 160	IM B34 FS 80 ~ 160		
示意图 Diagram						
电动机订货号第 14 位号上 对应的字母 Letter, position 14 th of Motor code	K	M	L	N		

- 注:
- ¹⁾ 室外使用时推荐使用护罩 (选件号 H00) ;
 - ²⁾ 当户外安装时, 推荐对电机轴采取防护措施, 避免水直接喷射到电机轴上。
- Notes:
- ¹⁾ At outdoor application, the using of protective cover (option code H00) is recommended;
 - ²⁾ At out door application the protection of shaft again jet-water is recommended.

轴承选型 Bearing Assignment

1MT0013 系列电动机标准配置深沟球轴承，这些轴承是密封的或可再润滑型的。

FS80 ~ 160 范围的电动机驱动端与非驱动端轴承浮动；FS180 ~ 355 电动机驱动端轴承浮动，非驱动端轴承固定。

标准配置的轴承可以承受一定的悬臂力，当电动机轴端承受的悬臂力较大时，可以考虑选择增强悬臂力的轴承设计（选件号：L22）。

FS80 ~ 250 范围电动机标配不带再润滑装置，FS160~250 可选择配置再润滑装置（选件号：L23）。FS280 ~ 355 范围的电动机标配再润滑装置。

1MT0013 series motors are supplied with the ball bearing as standard. These bearings are either of the sealed or regreasable type.

For FS80 ~ 160, the floating bearings are assembled; for FS180 ~ 355, floating bearing at DE, and fixed bearing at NDE assembled.

The standard bearing can endure a maximum cantilever force, the increased cantilever bearing design (Option code: L22) should be considered.

As standard, FS80 ~ 250 motors are not with regreasing device, but re-greasing device (Option code: L23) can be configured for FS160~250. FS280~355 motors with regreasable bearing and regreasing device is configured as standard.

机座号 Frame size	极数 Pole	标准配置 Standard design			增强悬臂力设计轴承(选件号L22) Increased cantilever-bearing (Option code:L22)		
		驱动端轴承 DE bearing	非驱动端轴承(水平安装) NDE bearing (Horizontal mounting)	非驱动端轴承(立式安装) NDE bearing (Vertical mounting)	驱动端轴承 DE bearing	非驱动端轴承(水平安装) NDE bearing (Horizontal mounting)	非驱动端轴承(立式安装) NDE bearing (Vertical mounting)
80	2,4,6	6204 2RZ C3	6204 2RZ C3	6204 2RZ C3	—	—	—
90	2,4,6	6205 2RZ C3	6205 2RZ C3	6205 2RZ C3	—	—	—
100	2,4,6	6206 2RZ C3	6206 2RZ C3	6206 2RZ C3	6306 2RZ C3	6206 2RZ C3	6206 2RZ C3
112	2,4,6	6206 2RZ C3	6206 2RZ C3	6206 2RZ C3	6306 2RZ C3	6206 2RZ C3	6206 2RZ C3
132	2,4,6,8	6208 2RZ C3	6208 2RZ C3	6208 2RZ C3	6308 2RZ C3	6208 2RZ C3	6208 2RZ C3
160	2,4,6,8	6209 2RZ C3	6209 2RZ C3	6209 2RZ C3	6309 2RZ C3	6209 2RZ C3	6209 2RZ C3
180	2,4,6,8	6310 2RZ C3	6310 2RZ C3	6310 2RZ C3	NU310	6310 2RZ C3	6310 2RZ C3
200	2,4,6,8	6312 2RZ C3	6312 2RZ C3	6312 2RZ C3	NU312	6312 2RZ C3	6312 2RZ C3
225	2,4,6,8	6313 2RZ C3	6313 2RZ C3	6313 2RZ C3	NU313	6313 2RZ C3	6313 2RZ C3
250	2,4,6,8	6315 C3	6315 C3	6315 C3	NU315	6315 C3	6315 C3
280	2,4,6,8	6317 C3	6317 C3	6317 C3	NU317	6317 C3	6317 C3
315	2	6316 C3	6316 C3	6316 C3	NU316	6316 C3	6316 C3
	4,6,8	6319 C3	6319 C3	6319 C3	NU319	6319 C3	6319 C3
355	2	6317 C3	6317 C3	7317	NU317	6317 C3	O.R.
	4,6,8	6322 C3	6322 C3	7322	NU322	6322 C3	O.R.

润滑脂寿命和再润滑周期

对于不可再润滑的轴承，其润滑脂寿命与轴承寿命相当。但是，这只能是在电机严格按照本样本中规定的技术数据运行。

对于以规定间隔再润滑的电机，轴承寿命可以延长，从而补偿不利因素，诸如温度、安装条件、转速、轴承规格和机械载荷造成的影响。

Grease life and re-greasing interval

For permanent lubrication, the bearing grease lifetime is matched to the bearing lifetime. This can, however, only be achieved if the motor is operated in accordance with the catalog specifications.

For motors which can be regreased at defined regreasing intervals, the bearing lifetime can be extended and/or unfavorable factors such as temperature, mounting conditions, speed, bearing size and mechanical load can be compensated.

润滑脂寿命和再润滑周期（电动机水平安装） Grease life (Horizontal installation)

机座号 Frame size	极数 Poles	润滑脂寿命 Grease lifetime up to CT 40 °C
持久润滑型轴承的润滑脂 Grease for permanent lubrication bearing		
80 ~ 250	2, 4, 6, 8	20000 或 (or) 40000 h
可再润滑型轴承的润滑脂 Grease for regreasable bearing		
180 ~ 250	2	4000 h
	4, 6, 8	8000 h
280 ~ 315	2	3000 h
	4, 6, 8	5000 h
355	2	3000 h
	4, 6, 8	4000 h

注：

¹⁾ 当环境温度每升高 10 °C，润滑脂寿命以及再润滑时间缩短一半。

²⁾ 40000 小时适用于电动机水平安装，且轴不受额外的轴向力影响；

Note:

¹⁾ If the coolant temperature is increased by 10 K, the grease lifetime and regreasing interval are halved.

²⁾ 40000 h apply to horizontally installed motors with coupling output without additional axial loads.

当电动机在非正常的条件下运行时，轴承的寿命会缩短。如下面几种情况：

- 当电动机的运行速度高于额定速度时，由于电动机的振动增大，使得轴承受到额外的径向力和轴向力，导致其寿命减少；
- 当环境或设备等因素引起电动机振动加大时，同样轴承也会因此受到额外的径向力和轴向力，而导致其寿命减少；
- 当环境温度每升高 10°C，润滑脂寿命以及再润滑时间缩短一半。

When the motor runs outside of normal conditions, the bearing life will be reduced, such as the following conditions.

- When motor runs beyond the rated speed, the increase of motor vibration will result in the extra radial and axial force on bearing. This will reduce the life of bearing;
- When the motor vibration increase due to the environment or other equipment, the bearing also will endure more radial and axial force. This also will reduce the life of bearing;
- If the coolant temperature is increased by 10 °C, the grease lifetime and regreasing interval is halved.

接线盒技术参数 Connection boxes technical data

机座号 Frame Size	主接线端子数 No. of main terminal	接线螺钉螺纹 Main terminal thread	引接线最大截面积(mm ²) Max. connectable cross-section	外接电缆直径 Cable diameter (mm) max. ~ min.	进线孔尺寸 Cable entry size	最多容纳辅助端子数 Max. auxiliary terminal
80	6	M4	1.5	13~18	M25x1.5+M16x1.5	12
90			4	18~25		
100						
112		6	12			
132						
160		M5	16	22~32	M40x1.5+M40x1.5	14
180		M6	25	32~38	M50x1.5+M50x1.5	14
200						
225		M8	35	37~44	M63x1.5+M63x1.5	14
250		M10	120			
280						
315		M12	150	37~44	M64x2 + M64x2	18
355		M16	240	42~54	M72x2 + M72x2	18

辅助端子进线孔尺寸 Cable entry size	允许外接电缆直径范围 (mm) Allowed outer cable diameter range (mm)	允许电缆的芯数范围 Allowed core number range of cable	引接线(导体)标称截面积(mm ²) Nominal section area of connection (conductor)(mm ²)
M16 x 1.5	8-11	2-7	1 mm ²
M20 x 1.5	11-14.3	8-10	1 mm ²
M27 x 2	13-20.2	12-27	1 mm ²

注意：

1. 电力电缆建议使用 YJV (GB/17206) 交联聚乙烯绝缘及聚氯乙烯护套 3+1 铜芯电缆。
2. 弱电信号控制电缆建议使用 KVV (GB/T9330) 聚氯乙烯绝缘聚乙烯护套铜芯截面 1 mm² 的多芯控制电缆。
3. 加热带线路为强电信号控制，请使用 KVV 铜芯截面 2 x 1mm² 的控制电缆单独进线。
4. 如果使用电缆直径不在防爆葛兰线径范围内，电机将失去防爆性能。
5. 如果需要使用铠装葛兰需特殊询价。

Note:

1. Power cables are recommended to use YJV (GB/17206) crosslinked polyethylene insulation and PVC sheath 3+1 copper core cable.
2. The control cable of weak current signal is recommended to use KVV (GB/T9330) polyvinyl chloride insulated sheath copper core section 1 mm² multi-core control cable.
3. The heating line is a strong signal control, please use the KVV copper core section 2 x 1mm² control cable to enter the line alone.
4. If the cable diameter is not in the range of explosion protection, the electric motor will lose the explosion-proof property.
5. If you need to use an armored gland, please make a special inquiry.

电气特性 Electrical design

额定输出

贝得电动机的额定功率是指电动机在连续运行的情况下 S1 (IEC 60034-1)，此时周围环境温度为 $-15\text{ }^{\circ}\text{C} \sim 40\text{ }^{\circ}\text{C}$ ，海拔高度不超过 1000 m。

电压、频率

IEC 60034-1 将电压和频率的偏差分为 A 类（电压偏差 $\pm 5\%$ ，频率偏差 $\pm 2\%$ ）和 B 类（电压偏差 $\pm 10\%$ ，频率偏差 $+3\% / -5\%$ ）。电动机均能够在 A 类和 B 类提供额定转矩。在 A 类中，温度比正常运行下温度大约提升 10 K。

Rated Output

Beide motors rated output powers means that the motor runs under continuous duty S1 (IEC 60034 - 1) operation when operated at ambient temperature from $-15\text{ }^{\circ}\text{C}$ to $40\text{ }^{\circ}\text{C}$ and at altitudes of up to 1000 m over sea.

Voltage and Frequency

IEC 60034-1 differentiates between Category A (combination of voltage deviation $\pm 5\%$ and frequency deviation $\pm 2\%$) and Category B (combination of voltage deviation $\pm 10\%$ and frequency deviation $+3\% / -5\%$) for voltage and frequency fluctuations. The motors can supply their rated torque in both Category A and B. In Category A, the temperature rise is approximately 10 K higher than during normal operation.

标准 60034 – 1 Standard 60034 – 1	类别 A Category A	类别 Category B
电压偏差 Voltage deviation	$\pm 5\%$	$\pm 10\%$
频率偏差 Frequency deviation	$\pm 2\%$	$+3\% / -5\%$
根据标准，不推荐电动机在 B 类情况下长时间运行 According to the standard, longer operation is not recommended for Category B.		

电气数据公差

- 效率 η
Prated $\leq 150\text{ kW}$: $-0.15 \times (1 - \eta)$
Prated $> 150\text{ kW}$: $-0.10 \times (1 - \eta)$
效率 η 为小于 1 的值
- 功率因数: $(1 - \cos \phi) / 6$
最小绝对值: 0.02
最大绝对值: 0.07
- 转差率: $\pm 20\%$ (电动机的偏差 $< 1\text{ kW} \pm 30\%$ 时是允许的)
- 堵转电流: $+20\%$
- 堵转转矩: $-15\% \sim +25\%$
- 最大转矩: -10%
- 转动惯量: $\pm 10\%$

Tolerance for electrical data

- Efficiency η at
Prated $\leq 150\text{ kW}$: $-0.15 \times (1 - \eta)$
Prated $> 150\text{ kW}$: $-0.10 \times (1 - \eta)$
With η being a decimal number
- Power factor: $(1 - \cos \phi) / 6$
Minimum absolute value: 0.02
Maximum absolute value: 0.07
- Slip $\pm 20\%$ (for motors $< 1\text{ kW} \pm 30\%$ is admissible)
- Locked-rotor current $+20\%$
- Locked-rotor torque -15% to $+25\%$
- Breakdown torque -10%
- Moment of inertia $\pm 10\%$

MLFB 介绍

电动机订货号 Order No.

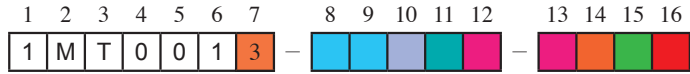

电机系列 Motor series
 粉尘防爆电机 Dust explosion proof motors

能耗等级 Efficiency grade
 3 = IE3, 中国能效等级 3 级 China Energy Efficiency Grade3

机座号编号 Code of frame size
 0D = 80 / 0E = 90 / 1A = 100 / 1B = 112 / 1C = 132 / 1D = 160
 1E = 180 / 2A = 200 / 2B = 225 / 2C = 250 / 2D = 280 3A=315 / 3B=355

极数编号 Code of poles
 A = 2 / B = 4 / C = 6 / D = 8

机座长度编号 Code of frame length
 0 or 1 = S (短机座 Short) / 2 or 3 or 4 = M (中机座 Medium) / 4 or 5 or 6 or 7 = L (长机座 Long)

电压, 连接方式和频率编号 Code of voltage, connections and frequency
 22 = 230VD/400VY 50Hz 35 = 415VD 50Hz
 21 = 220VD/380VY 50Hz 23 = 240VD/415VY 50Hz 90 = 特殊电压与频率 special voltage & frequency
 33 = 380VD/660VY 50Hz 34 = 400VD/690VY 50Hz

结构和安装方式编号 Code of construction and mounting type
 A = IM B3 J = IM B35 T = IM B6 V = IM B8 N = IM B34 W = IM V15 G = IM V1 M = IM V18
 F = IM B5 K = IM B14 U = IM B7 C = IM V5 D = IM V6 Y = IM V35 H = IM V3 L = IM V19

绕组保护编号 Code of winding protection
 A = 无绕组保护 without winding protection
 B = 绕组带一组三芯串联的 PTC 热敏电阻用于跳闸 3 PTC thermistors for tripping
 C = 绕组带两组三芯串联的 PTC 热敏电阻用于报警和跳闸 6 PTC thermistors for alarm and tripping
 H = 绕组带 3 个 Pt100 测温元件 3 resistance thermometers Pt100
 J = 绕组带 6 个 Pt100 测温元件 6 resistance thermometers Pt100

接线盒位置编号 (从驱动端看) Code location of connection box (view from drive end)
 4 = 顶端出线 top / 5 = 右端出线 on RHS / 6 = 左端出线 on LHS

选型技术数据表 Technical data table

中国能效等级3级, IE3

机座号 Frame Size	额定 功率 Rated Output	型号 OrderNo.	额定 转速 Rated Speed	效率—参照 GB18613-2020 效率等级 3 Efficiency is in accordance with the efficiency level 3 of GB18613-2020				额定 转矩 Rated torque	起动 电流 Starting Current	起动 转矩 Starting torque	最大 转矩 Max torque	转动惯量 Moment of inertia(J)	噪音 ¹⁾ Noise LpFA	重量 Weight IMB3
				效率 Efficiency at (50HZ) 4/4 load	效率 Efficiency at (50HZ) 3/4 load	功率 因数 Power factor	额定 电流 Rated current							
	kW		rpm	%	%		A	Nm	直接起动对额定转矩 (电流)的倍数 For direct-on-line starting as multiple of the rated			kgm ²	dB(A)	Kg
3000rpm 2- pole 220VD380VY 50HZ														
80M	0.75	1MT0013-0DA22-1 □□□	2835	80.7	82.9	0.86	1.64	2.5	6.0	2.4	3.0	0.00208	51	17.5
80M	1.1	1MT0013-0DA32-1 □□□	2850	82.7	84.0	0.83	2.45	3.7	6.5	2.6	3.4	0.00154	51	18.5
90S	1.5	1MT0013-0EA02-1 □□□	2870	84.2	84.8	0.86	3.15	5.0	7.0	2.0	3.0	0.00276	55	23
90L	2.2	1MT0013-0EA42-1 □□□	2890	85.9	87.2	0.88	4.4	7.3	7.5	2.8	3.6	0.00356	55	28
100L	3	1MT0013-1AA42-1 □□□	2865	87.1	88.3	0.87	6	10.0	7.8	3.3	3.6	0.00462	62	39
3000rpm 2- pole 380VD/660VY 50HZ														
112M	4	1MT0013-1BA23-3 □□□	2915	88.1	89.6	0.90	7.7	13.1	7.8	2.6	3.6	0.0088	65	47
132S	5.5	1MT0013-1CA03-3 □□□	2930	89.2	90.2	0.89	10.5	17.9	7.5	2.3	3.6	0.0185	67	59
132S	7.5	1MT0013-1CA13-3 □□□	2930	90.1	91.5	0.90	14.1	24.4	7.5	2.3	3.6	0.0232	67	66
160M	11	1MT0013-1DA23-3 □□□	2935	91.2	92.0	0.89	20.5	35.8	7.5	2.3	3.4	0.039	69	98
160M	15	1MT0013-1DA33-3 □□□	2935	91.9	92.6	0.89	28	48.8	7.5	2.4	3.4	0.0472	69	109
160L	18.5	1MT0013-1DA43-3 □□□	2935	92.4	93.0	0.89	34	60.2	7.8	2.4	3.4	0.0577	69	126
180M	22	1MT0013-1EA23-3 □□□	2950	92.7	93.0	0.89	40.5	71.2	7.8	2.4	3.4	0.077	70	171
200L	30	1MT0013-2AA43-3 □□□	2955	93.3	93.4	0.89	55	97.0	7.8	2.4	3.4	0.133	71	232
200L	37	1MT0013-2AA53-3 □□□	2955	93.7	93.9	0.89	67	120	7.8	2.4	3.4	0.152	71	265
225M	45	1MT0013-2BA23-3 □□□	2960	94.0	94.3	0.89	82	145	7.8	2.4	3.2	0.254	72	333
250M	55	1MT0013-2CA23-3 □□□	2975	94.3	94.1	0.89	100	177	7.8	2.6	3.2	0.443	75	414
280S	75	1MT0013-2DA03-3 □□□	2975	94.7	94.8	0.89	135	241	7.5	2.8	3.0	0.78	77	530
280M	90	1MT0013-2DA23-3 □□□	2975	95.0	95.3	0.90	160	289	7.5	2.8	3.4	0.95	77	585
315S	110	1MT0013-3AA03-3 □□□	2985	95.2	95.1	0.90	195	352	7.9	2.3	2.6	1.57	78	780
315M	132	1MT0013-3AA23-3 □□□	2982	95.4	95.3	0.90	235	423	7.9	2.3	2.6	1.66	78	820
315L	160	1MT0013-3AA53-3 □□□	2982	95.6	95.7	0.91	280	512	7.9	2.3	2.6	1.98	78	950
315L	185	1MT0013-3AA63-3 □□□	2978	95.7	95.9	0.92	320	593	8.5	2.3	2.6	2.38	78	1060
315L	200	1MT0013-3AA73-3 □□□	2982	95.8	95.9	0.92	345	641	8.5	2.8	3.2	2.38	81	1070
355M	220	1MT0013-3BA23-3 □□□	2986	95.8	95.4	0.90	390	704	8.5	2.2	2.8	2.63	85	1360
355M	250	1MT0013-3BA33-3 □□□	2985	95.8	95.7	0.90	440	800	8.0	2.2	2.8	2.63	85	1370
355L	280	1MT0013-3BA53-3 □□□	2988	95.8	95.7	0.90	495	895	8.5	2.2	2.8	3.23	85	1590
355L	315	1MT0013-3BA63-3 □□□	2982	95.8	95.8	0.90	560	1009	8.0	2.2	2.8	3.23	85	1610

注:
¹⁾ 当电动机在50Hz电源供电空载运行时, 噪音容差为+3dB。当在60Hz
 电源下空载运行时, 噪音容差为+4dB。

Note:
¹⁾ Noise value is only applicable to the direct power supply and the condition
 of no-load operation. If the motor in 50Hz power supply, the tolerance is
 +3dB. If the motor in 60Hz power supply, the tolerance is +4dB.

选型技术数据表 Technical data table

中国能效等级3级, IE3

机座号 Frame Size	额定 功率 Rated Output	型号 OrderNo.	额定 转速 Rated Speed	效率—参照 GB18613-2020 效率等级 3 Efficiency is in accordance with the efficiency level 3 of GB18613-2020				额定 转矩 Rated torque	起动电流 Starting Current	起动转矩 Starting torque	最大 转矩 Max torque	转动惯量 Moment of inertia(J)	噪音 ¹⁾ Noise Lp(A)	重量 Weight IMB3
				效率 Efficiency at (50HZ) 4/4 load	效率 Efficiency at (50HZ) 3/4 load	功率 因数 Power factor	额定 电流 Rated current							
	kW		rpm	%	%		A	Nm	直接起动对额定转矩 (电流)的倍数 For direct-on-line starting as multiple of the rated			kgm ²	dB(A)	Kg
1500rpm 4- pole 220VD/380VY 50HZ														
80M	0.55	1MT0013-0DB22-1 □□□	1440	80.8	81.8	0.76	1.36	3.6	5.5	2.2	3.2	0.0216	45	18.0
80M	0.75	1MT0013-0DB32-1 □□□	1440	82.5	82.9	0.75	1.84	5.0	6.0	2.6	3.7	0.0025	45	19.5
90S	1.1	1MT0013-0EB02-1 □□□	1430	84.1	85.1	0.79	2.5	7.3	6.5	2.7	3.7	0.00389	47	23
90L	1.5	1MT0013-0EB42-1 □□□	1440	85.3	86.0	0.79	3.4	9.9	6.5	2.8	3.8	0.00499	47	28
100L	2.2	1MT0013-1AB42-1 □□□	1440	86.7	87.1	0.82	4.7	14.6	8.3	3.0	4.0	0.01125	52	41
100L	3	1MT0013-1AB52-1 □□□	1440	87.7	88.1	0.82	6.3	19.9	8.3	3.0	4.0	0.01313	52	45
1500rpm 4- pole 380VD/660VY 50HZ														
112M	4	1MT0013-1BB23-3 □□□	1450	88.6	89.6	0.82	8.4	26.3	8.3	3.7	4.6	0.0149	53	52
132S	5.5	1MT0013-1CB03-3 □□□	1455	89.6	90.9	0.84	11.1	36.1	7.8	2.4	3.8	0.0285	59	66
132M	7.5	1MT0013-1CB23-3 □□□	1455	90.4	91.7	0.85	14.8	49.2	7.8	2.4	3.8	0.0356	59	82
160M	11	1MT0013-1DB23-3 □□□	1465	91.4	92.4	0.86	21.5	71.7	7.8	2.6	3.8	0.0648	61	108
160L	15	1MT0013-1DB43-3 □□□	1465	92.1	92.9	0.86	29	97.8	8.2	2.6	3.8	0.0811	61	126
180M	18.5	1MT0013-1EB23-3 □□□	1470	92.6	93.0	0.83	36.5	120	7.8	2.6	3.6	0.126	63	169
180L	22	1MT0013-1EB43-3 □□□	1470	93.0	93.7	0.83	43.5	143	7.8	2.6	3.6	0.146	63	191
200L	30	1MT0013-2AB43-3 □□□	1475	93.6	94.3	0.84	58	194	7.8	2.6	3.6	0.22	63	246
225S	37	1MT0013-2BB03-3 □□□	1482	93.9	94.1	0.85	70	238	8.3	3.0	3.6	0.461	65	307
225M	45	1MT0013-2BB23-3 □□□	1482	94.2	94.2	0.85	85	290	8.3	3.0	3.6	0.479	65	336
250M	55	1MT0013-2CB23-3 □□□	1485	94.6	95.0	0.86	103	354	7.6	2.6	3.3	0.82	66	434
280S	75	1MT0013-2DB03-3 □□□	1485	95.0	95.3	0.86	139	482	7.6	2.8	3.0	1.31	66	540
280M	90	1MT0013-2DB23-3 □□□	1485	95.2	95.6	0.87	165	579	7.6	2.8	3.0	1.69	66	655
315S	110	1MT0013-3AB03-3 □□□	1488	95.4	95.7	0.87	200	706	7.9	3.0	3.0	2.39	74	735
315M	132	1MT0013-3AB23-3 □□□	1488	95.6	95.9	0.87	240	847	7.9	3.0	3.0	3.01	74	895
315L	160	1MT0013-3AB53-3 □□□	1488	95.8	96.1	0.87	290	1027	7.9	3.0	3.0	3.33	74	985
315L	185	1MT0013-3AB63-3 □□□	1488	95.9	96.2	0.87	335	1187	8.5	3.0	3.0	3.77	74	1050
315L	200	1MT0013-3AB73-3 □□□	1490	96.0	96.3	0.88	360	1282	8.5	3.0	3.0	4.13	74	1100
355M	220	1MT0013-3BB23-3 □□□	1490	96.0	96.0	0.88	395	1410	8.0	2.0	3.2	4.97	81	1520
355M	250	1MT0013-3BB33-3 □□□	1490	96.0	96.0	0.88	450	1602	7.8	1.8	2.9	4.97	81	1550
355L	280	1MT0013-3BB53-3 □□□	1490	96.0	96.1	0.88	500	1795	7.8	1.8	2.9	6.52	81	1670
355L	315	1MT0013-3BB63-3 □□□	1490	96.0	96.1	0.88	570	2019	8.0	1.8	2.9	7.06	81	1760

注:
¹⁾ 当电动机在50Hz电源供电空载运行时, 噪音容差为+3dB。当在60Hz电源下空载运行时, 噪音容差为+4dB。

Note:
¹⁾ Noise value is only applicable to the direct power supply and the condition of no-load operation. If the motor in 50Hz power supply, the tolerance is +3dB. If the motor in 60Hz power supply, the tolerance is +4dB.

选型技术数据表 Technical data table

中国能效等级3级, IE3

机座号 Frame Size	额定 功率 Rated Output	型号 OrderNo.	额定 转速 Rated Speed	效率—参照 GB18613-2020 效率等级 3 Efficiency is in accordance with the efficiency level 3 of GB18613-2020				额定 转矩 Rated torque	起动电流 Starting Current	起动转矩 Starting torque	最大 转矩 Max torque	转动惯量 Moment of inertia(J)	噪音 ¹⁾ Noise Lp(A)	重量 Weight IMB3
				效率 Efficiency at (50HZ) 4/4 load	效率 Efficiency at (50HZ) 3/4 load	功率 因数 Power factor	额定 电流 Rated current							
	kW		rpm	%	%		A	Nm	直接起动对额定转矩 (电流)的倍数 For direct-on-line starting as multiple of the rated			kgm ²	dB(A)	Kg
1000rpm 6- pole 220VD/380VY 50HZ														
80M	0.55	1MT0013-0DC32-1 □□□	935	77.2	77.5	0.67	1.62	5.6	5.0	2.6	3.2	0.0031	44	20
90S	0.75	1MT0013-0EC02-1 □□□	940	78.9	80.3	0.70	2.05	7.6	5.0	2.4	3.2	0.00436	45	25
90L	1.1	1MT0013-0EC42-1 □□□	945	81.0	81.6	0.69	3	11.1	5.5	2.7	3.5	0.00513	45	28
100L	1.5	1MT0013-1AC42-1 □□□	950	82.5	84.1	0.74	3.75	15.1	5.5	2.5	3.5	0.01136	49	42
112M	2.2	1MT0013-1BC22-1 □□□	945	84.3	86.1	0.74	5.4	22.2	6.0	2.7	3.4	0.01451	53	50
132S	3	1MT0013-1CC02-1 □□□	965	85.6	86.6	0.75	7.1	29.7	6.0	2.7	4.0	0.02666	57	63
1000rpm 6- pole 380VD/660VY 50HZ														
132M	4	1MT0013-1CC23-3 □□□	955	86.8	88.5	0.75	9.3	40.0	6.0	2.7	3.4	0.0305	57	76
132M	5.5	1MT0013-1CC33-3 □□□	960	88.0	89.2	0.76	12.5	54.7	6.5	2.7	4.0	0.0413	57	87
160M	7.5	1MT0013-1DC23-3 □□□	980	89.1	90.4	0.78	16.4	73.1	7.0	2.7	3.6	0.126	61	105
160L	11	1MT0013-1DC43-3 □□□	980	90.3	90.3	0.77	24	107	7.0	2.7	3.6	0.1717	61	134
180L	15	1MT0013-1EC43-3 □□□	975	91.2	92.1	0.80	31	147	7.0	2.3	3.0	0.185	59	172
200L	18.5	1MT0013-2AC43-3 □□□	978	91.7	92.5	0.80	38.5	181	7.0	2.3	3.0	0.284	59	224
200L	22	1MT0013-2AC53-3 □□□	980	92.2	93.1	0.80	45.5	214	7.0	2.4	3.0	0.327	59	240
225M	30	1MT0013-2BC23-3 □□□	982	92.9	93.9	0.83	59	292	7.6	2.4	3.0	0.71	60	333
250M	37	1MT0013-2CC23-3 □□□	985	93.3	94.1	0.84	72	359	7.6	2.6	3.0	1.03	62	418
280S	45	1MT0013-2DC03-3 □□□	988	93.7	94.5	0.84	87	435	7.8	3.2	3.0	1.4	64	495
280M	55	1MT0013-2DC23-3 □□□	988	94.1	94.6	0.84	106	532	7.8	3.2	3.0	1.7	64	555
315S	75	1MT0013-3AC03-3 □□□	990	94.6	95.0	0.84	143	723	7.8	2.4	3.0	2.75	69	720
315M	90	1MT0013-3AC23-3 □□□	990	94.9	95.3	0.84	172	868	7.8	2.4	3.0	3.34	69	830
315L	110	1MT0013-3AC53-3 □□□	991	95.1	95.3	0.85	205	1060	7.8	2.6	3.0	4.32	69	1000
315L	132	1MT0013-3AC63-3 □□□	991	95.4	95.7	0.85	245	1272	7.8	2.6	3.0	4.62	69	1040
355M	160	1MT0013-3BC23-3 □□□	994	95.6	95.7	0.84	305	1537	8.5	3.0	2.4	10.40	71	1630
355M	185	1MT0013-3BC33-3 □□□	993	95.7	95.8	0.84	350	1779	8.5	3.0	2.4	10.40	71	1650
355M	200	1MT0013-3BC43-3 □□□	993	95.8	95.9	0.84	380	1923	8.5	3.0	2.4	10.87	71	1700
355L	220	1MT0013-3BC53-3 □□□	993	95.8	96.0	0.84	415	2116	8.5	3.0	2.4	12.86	71	1940
355L	250	1MT0013-3BC63-3 □□□	992	95.8	96.1	0.84	470	2407	8.5	3.0	2.4	12.86	71	1960

注：
¹⁾ 当电动机在50Hz电源供电空载运行时，噪音容差为+3dB。当在60Hz电源下空载运行时，噪音容差为+4dB。

Note:
¹⁾ Noise value is only applicable to the direct power supply and the condition of no-load operation. If the motor in 50Hz power supply, the tolerance is +3dB. If the motor in 60Hz power supply, the tolerance is +4dB.

选型技术数据表 Technical data table

中国能效等级3级, IE3

机座号 Frame Size	额定 功率 Rated Output	型号 OrderNo.	额定 转速 Rated Speed	效率—参照 GB18613-2020 效率等级 3 Efficiency is in accordance with the efficiency level 3 of GB18613-2020				额定 转矩 Rated torque	起动 电流 Starting Current	起动 转矩 Starting torque	最大 转矩 Max torque	转动惯量 Moment of inertia(J)	噪音 ¹⁾ Noise Lp(A)	重量 Weight IMB3
				效率 Efficiency at (50HZ) 4/4 load	效率 Efficiency at (50HZ) 3/4 load	功率 因数 Power factor	额定 电流 Rated current							
	kW		rpm	%	%		A	Nm	直接起动对额定转矩 (电流)的倍数 For direct-on-line starting as multiple of the rated			kgm ²	dB(A)	Kg
750rpm 8-pole 220VD/380VY 50HZ														
132S	2.2	1MT0013-1CD02-1 □□□□	725	81.9	82.6	0.73	5.6	29	5.5	1.8	3.0	0.039	51	55
132M	3	1MT0013-1CD22-1 □□□□	720	83.5	84.5	0.74	7.4	39.8	5.5	1.8	3.0	0.054	51	74
750rpm 8-pole 380VD/660VY 50HZ														
160M	4	1MT0013-1DD23-3 □□□□	728	84.8	86.4	0.74	9.7	52.5	5.5	1.7	2.8	0.092	55	91
160M	5.5	1MT0013-1DD33-3 □□□□	732	86.2	87.1	0.74	13.1	71.8	6.0	1.7	3.0	0.124	55	102
160L	7.5	1MT0013-1DD43-3 □□□□	732	87.3	88.3	0.74	17.6	97.8	6.0	1.8	3.0	0.16	55	116
180L	11	1MT0013-1ED43-3 □□□□	720	88.6	89.9	0.74	25.5	146	5.5	2.0	3.0	0.255	60	197
200L	15	1MT0013-2AD53-3 □□□□	728	89.6	90.2	0.73	35	197	6.5	2.5	3.5	0.411	61	255
225S	18.5	1MT0013-2BD03-3 □□□□	732	90.1	90.9	0.75	41.5	241	6.5	2.0	3.0	0.592	58	274
225M	22	1MT0013-2BD23-3 □□□□	732	90.6	91.5	0.75	49	287	6.5	2.0	2.5	0.609	58	298
250M	30	1MT0013-2CD23-3 □□□□	735	91.3	92.1	0.79	63	390	6.5	2.0	3.0	1.027	67	382
280S	37	1MT0013-2DD03-3 □□□□	735	91.8	92.8	0.79	78	481	5.5	2.4	2.5	1.41	69	460
280M	45	1MT0013-2DD23-3 □□□□	735	92.2	93.1	0.80	93	585	6.0	2.4	2.5	1.76	69	560
315S	55	1MT0013-3AD03-3 □□□□	738	92.5	93.0	0.81	112	710	6.2	1.8	2.9	2.09	70	620
315M	75	1MT0013-3AD23-3 □□□□	738	93.1	93.6	0.81	151	970	6.7	1.8	2.5	2.60	70	730
315L	90	1MT0013-3AD53-3 □□□□	738	93.4	93.9	0.82	179	1165	5.9	1.8	2.3	3.31	70	850
315L	110	1MT0013-3AD63-3 □□□□	738	93.7	94.2	0.82	220	1418	7.1	2.3	3.0	4.13	70	960
355M	132	1MT0013-3BD23-3 □□□□	743	94.0	94.5	0.81	265	1699	7.1	2.2	2.4	8.14	77	1430
355M	160	1MT0013-3BD33-3 □□□□	742	94.3	94.8	0.81	320	2059	7.1	2.2	2.4	9.53	77	1560
355L	185	1MT0013-3BD53-3 □□□□	742	94.6	95.0	0.82	360	2382	7.1	2.0	2.1	11.30	77	1800
355L	200	1MT0013-3BD63-3 □□□□	742	94.6	95.0	0.83	385	2576	7.4	2.0	2.1	12.70	77	1930

注:

¹⁾ 当电动机在50Hz电源供电空载运行时, 噪音容差为+3dB。当在60Hz电源下空载运行时, 噪音容差为+4dB。

Note:

¹⁾ Noise value is only applicable to the direct power supply and the condition of no-load operation. If the motor in 50Hz power supply, the tolerance is +3dB. If the motor in 60Hz power supply, the tolerance is +4dB.

选件 Options

选件号 Option Code	描述 Description	应用范围 Frame size scope
电压和频率 Voltage and Frequency		
1MT0013- □□□□ 2-1 □□□□	220VD / 380VY 50Hz; 440VY 60Hz (60Hz output 60Hz 输出)	FS80-280
1MT0013- □□□□ 3-3 □□□□	380VD / 660VY 50Hz; 440VD 60Hz (60Hz output 60Hz 输出)	FS80-355
1MT0013- □□□□ 2-2 □□□□	230VD / 400VY 50Hz; 460VY 60Hz (60Hz output 60Hz 输出)	FS80-280
1MT0013- □□□□ 3-4 □□□□	400VD / 690VY 50Hz; 460VD 60Hz (60Hz output 60Hz 输出)	FS80-355
1MT0013- □□□□ 2-3 □□□□	240VD / 415VY 50Hz	FS80-280
1MT0013- □□□□ 3-5 □□□□	415VD 50Hz	FS80-355
M1C	440VY 60Hz (60Hz output 60Hz 输出)	FS80-280
M1D	440VD 60Hz (60Hz output 60Hz 输出)	FS80-355
M1E	460VY 60Hz (60Hz output 60Hz 输出)	FS80-280
M1F	460VD 60Hz (60Hz output 60Hz 输出)	FS80-355
M2C	440VY 60Hz (50Hz output 50Hz 输出)	FS80-280
M2D	440VD 60Hz (50Hz output 50Hz 输出)	FS80-355
M2E	460VY 60Hz (50Hz output 50Hz 输出)	FS80-280
M2F	460VD 60Hz (50Hz output 50Hz 输出)	FS80-355
绕组保护 Winding protection		
1MT0013- □□□□□ - □□ A □	无绕组保护 Without winding protection	FS80-355
1MT0013- □□□□□ - □□ B □	三个 PTC 热敏电阻用于跳闸, 需用 2 个辅助接线端子 Motor protection with PTC thermistors with 3 embedded temperature sensors for tripping, need 2 terminals	FS80-355
1MT0013- □□□□□ - □□ C □	六个 PTC 热敏电阻用于报警和跳闸, 需用 4 个辅助接线端子 Motor protection with PTC thermistors with 6 embedded temperature sensors for alarm and tripping, need 4 terminals	FS80-355
1MT0013- □□□□□ - □□ H □	三个 PT100 传感器监测绕组温度, 需用 6 个辅助端子 Installation of 3 PT100 resistance thermometers in stator winding, need 6 terminals	FS100-355
1MT0013- □□□□□ - □□ J □	六个 PT100 传感器监测绕组温度, 需用 12 个辅助端子 Installation of 6 PT100 resistance thermometers in stator winding, need 12 terminals	FS100-355
N10	H 级绝缘系统 (180 °C) 180 °C (H) class insulation system	FS80-355
Q04	220V 防潮加热带 Anti-condensation heaters for 220V	FS80-355
接线盒 Connection box		
R10 ¹⁾	接线盒旋转 90 度, 出线口朝驱动端 Rotation of terminal box by 90°, entry from DE	FS132-355
R11	接线盒旋转 90 度, 出线口朝非驱动端 Rotation of terminal box by 90°, entry from NDE	FS80-355
R12	接线盒旋转 180 度 Rotation of terminal box by 180°	FS80-355
R15	配备一个金属葛兰和一个金属闷盖 1 metal cable glands+1 metal cover	FS80-355
V9D	配置一个尼龙葛兰和一个尼龙闷盖 1 nylon cable gland+1 nylon cover	FS80-355

选件 Options

选件号 Option Code	描述 Description	应用范围 Frame size scope
轴承 Bearing		
Q72	两个 PT100 传感器监测轴承温度 Installation of 2 PT100 screw-in resistance thermometers for bearing	FS180-355
L81	其他进口品牌轴承 Other imported brand bearing	FS80-355
L80	SKF 轴承 SKF bearings	FS80-355
L22 ²⁾	增强悬臂力 Increased cantilever force	FS100-355
L23 ³⁾	再润滑装置 Re-greasing device	FS160-250
L20	驱动端轴承固定 Located bearing at DE	FS80-160
机械防护 Mechanical design and protection grade		
H00 ⁴⁾	防雨帽 Motor with protective cover	FS80-355
H70	第二外部接地 2nd External grounding	FS80-355
铭牌和测试报告 Nameplate and Testing Certificate		
B80	例行检测报告 Routine test report	FS80-355
油漆 Paint finish		
S01	不喷面漆，仅有底漆 Unpainted, only primed	FS80-355
包装 Packing		
B90	包装 (FS80 ~ 132 电动机采用纸箱包装, FS160 ~ 355 电动机采用木箱包装) Packing(FS80~132 motors adopt the carton packaging, FS160~355 motors adopt the wooden cases packaging)	FS80-355

¹⁾ 选择此项时需留意安装环境，请确认进线孔前方有足够的空间用于接入电缆；

²⁾ FS100和FS112不能选L22+L20复合选项；

³⁾ 对于FS280及以上加排油装置是标配；

⁴⁾ 仅适用于IMV1、IMV5、IMV15、IMV18安装结构型式。

¹⁾ When ordering this option, please take care about the installation location that whether there is enough space for cable inserting.

²⁾ For FS100 and FS112, L22+L20 can't be selected.

³⁾ Re-grease device is configured as standard for FS280 and above.

⁴⁾ It is applicable only for IMV1, IMV5, IMV15 and IMV18.

外形尺寸 Dimension drawings

IM B3 安装结构型式 IM B3 construction type

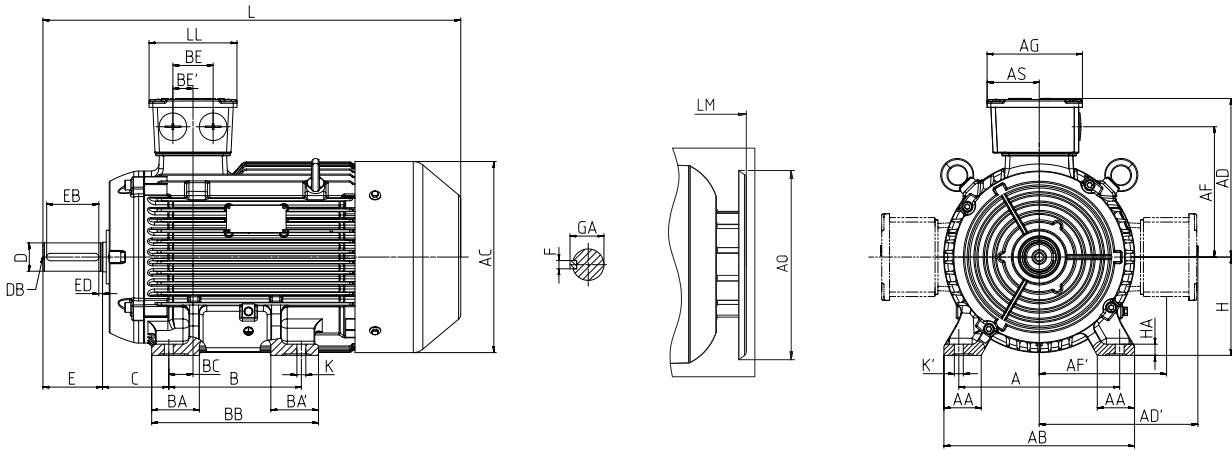

IM B35 安装结构型式 IM B35 construction type

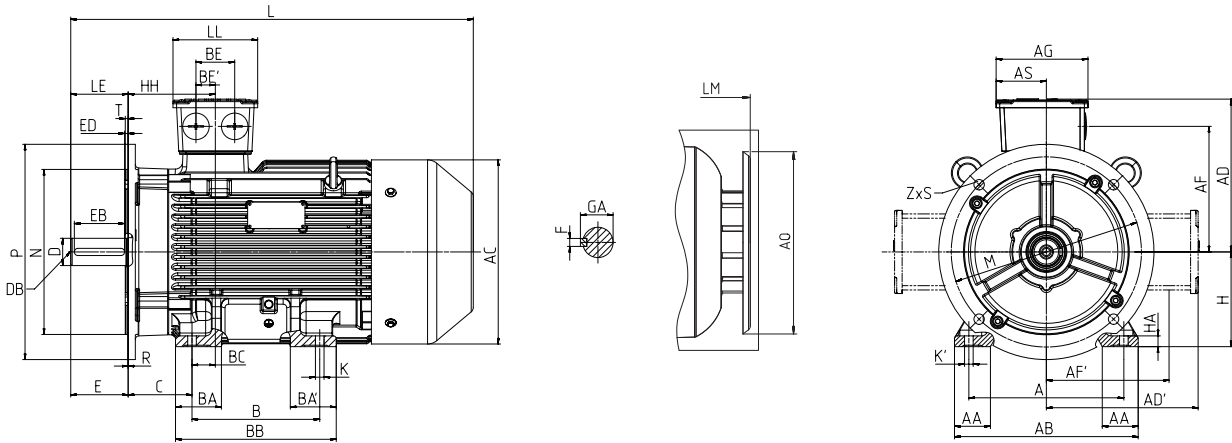

机座号 Frame size	订货号 MLFB 1MT0013	极数 Poles	尺寸及公差 /mm Dimension and toleranc										GA	H 基本尺寸 Dimension
			A	B	C		D		E		F			
					基本尺寸 Dimension	极限偏差 Tolerance	基本尺寸 Dimension	极限偏差 Tolerance	基本尺寸 Dimension	极限偏差 Tolerance	基本尺寸 Dimension	极限偏差 Tolerance		
80M	0DA2, 0DA3, 0DB2, 0DB3, 0DC3	2,4,6	125	100	50	± 1.5	19	+ 0.009 - 0.004	40	± 0.31	6	0 - 0.030	21.5	80
90S	0EA0, 0EB0, 0EC0	2,4,6	140	100	56	± 1.5	24	+ 0.009 - 0.004	50	± 0.31	8	0 - 0.036	27	90
90L	0EA4, 0EB4, 0EC4	2,4,6	140	125	56	± 1.5	24	+ 0.009 - 0.004	50	± 0.31	8	0 - 0.036	27	90
100L	1AA4, 1AB4, 1AB5, 1AC4	2,4,6	160	140	63	± 2.0	28	+ 0.009 - 0.004	60	± 0.37	8	0 - 0.036	31	100
112M	1BA2, 1BB2, 1BC2	2,4,6	190	140	70	± 2.0	28	+ 0.009 - 0.004	60	± 0.37	8	0 - 0.036	31	112
132S	1CA0, 1CA1, 1CB0, 1CC0, 1CD0	2,4,6,8	216	140	89	± 2.0	38	+ 0.018 + 0.002	80	± 0.37	10	0 - 0.036	41	132
132M	1CB2, 1CC2, 1CC3, 1CD2	4,6,8	216	178	89	± 2.0	38	+ 0.018 + 0.002	80	± 0.37	10	0 - 0.036	41	132
160M	1DA2, 1DA3, 1DB2, 1DC2, 1DD2, 1DD3	2,4,6,8	254	210	108	± 3.0	42	+ 0.018 + 0.002	110	± 0.43	12	0 - 0.043	45	160
160L	1DA4, 1DB4, 1DC4, 1DD4	2,4,6,8	254	254	108	± 3.0	42	+ 0.018 + 0.002	110	± 0.43	12	0 - 0.043	45	160
180M	1EA2, 1EB2	2,4	279	241	121	± 3.0	48	+ 0.018 + 0.002	110	± 0.43	14	0 - 0.043	51.5	180
180L	1EB4, 1EC4, 1ED4	4,6,8	279	279	121	± 3.0	48	+ 0.018 + 0.002	110	± 0.43	14	0 - 0.043	51.5	180

¹⁾ 此尺寸为 80~280 顶出线、右出线及 80~160 左出线值，当 FS180~280 左出线时见表 2

The data for terminal box on top or right in FS80~280 and terminal box on left in FS80~160. When terminal box on left in FS180~280, please find the data in table 2.

IM B5 安装结构型式 IM B5 construction type

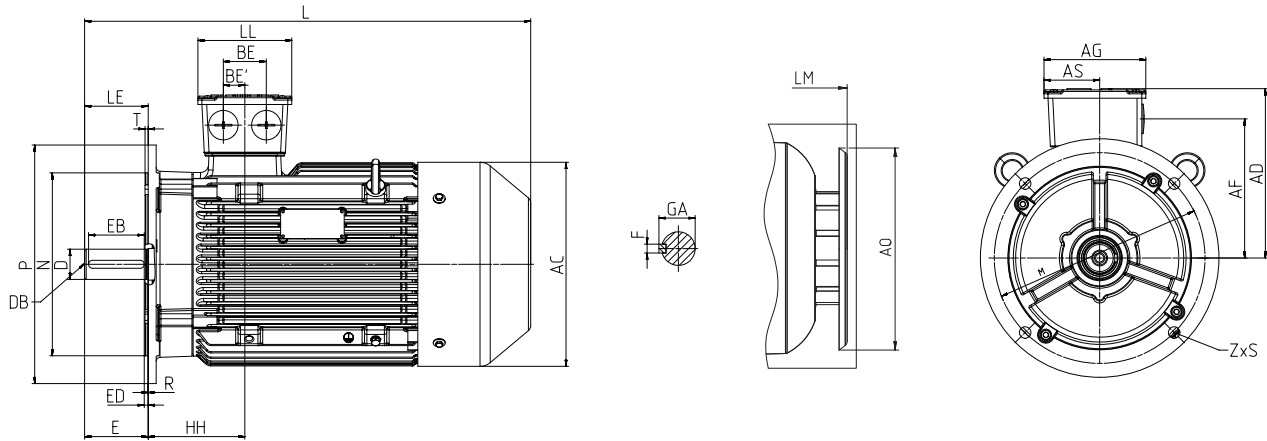

IM B14 安装结构型式 Type of construction IM B14

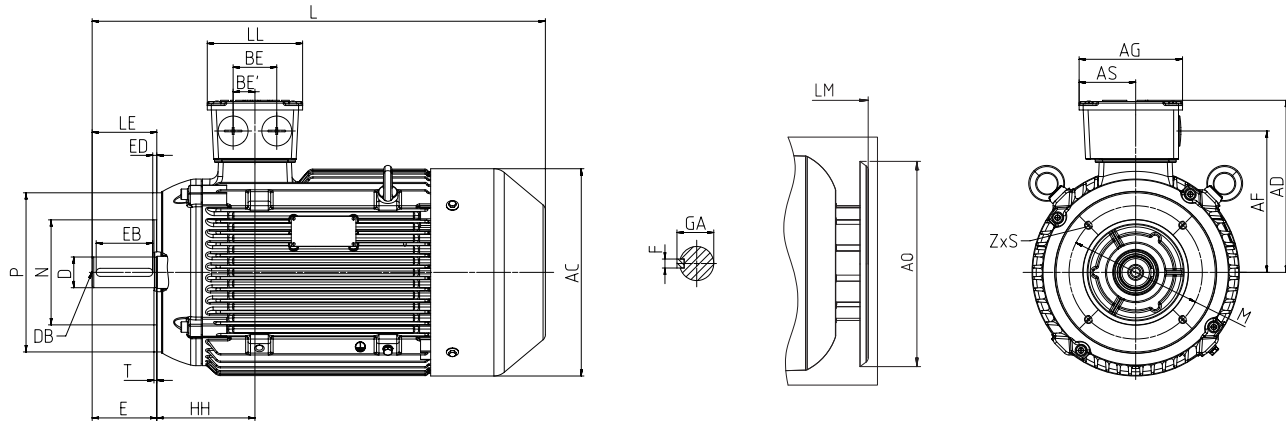

尺寸及公差 /mm Dimension and toleranc

H	K/K'		AB	AC	AD/ AD'	L	AA	BA/ BA' 1)	AF/ AF'	AG	AS	BB ¹⁾	BE	HA	LL	DB	EB		ED	AQ	LM	HH	R
	极限偏差 Tolerance	基本尺寸 Dimension															极限偏差 Tolerance	基本尺寸 Dimension					
0 - 0.5	10	+ 0.36 0	160	165	145	335	40	50	108	120	70	140	42	10	115	M6x16	32	+ 0.30 0	4	145	385	76	0
0 - 0.5	10	+ 0.36 0	180	180	155	375	40	50	120	120	70	145	42	10	115	M8x19	40	+ 0.30 0	5	165	425	79	0
0 - 0.5	10	+ 0.36 0	180	180	155	400	40	50	120	120	70	170	42	10	115	M8x19	40	+ 0.30 0	5	165	450	79	0
0 - 0.5	12	+ 0.43 0	200	205	180	465	45	50	140	130	75	180	54	12	125	M10x22	50	+ 0.30 0	5	185	515	94	0
0 - 0.5	12	+ 0.43 0	230	225	193	455	50	55	152	130	75	185	54	15	125	M10x22	50	+ 0.30 0	5	205	505	92	0
0 - 0.5	12	+ 0.43 0	260	260	213	510	55	70	175	130	75	190	54	15	125	M12x28	70	+ 0.30 0	5	240	570	122	0
0 - 0.5	12	+ 0.43 0	260	260	213	565	55	70	175	130	75	230	54	15	125	M12x28	70	+ 0.30 0	5	240	615	122	0
0 - 0.5	15	+ 0.43 0	320	320	255	620	65	75	206	190	100	265	68	20	165	M16x36	100	+ 0.50 0	5	295	680	159	0
0 - 0.5	15	+ 0.43 0	320	320	255	660	65	75	206	190	100	305	68	20	165	M16x36	100	+ 0.50 0	5	295	740	159	0
0 - 0.5	15	+ 0.43 0	340	360	275	725	70	85	223	190	100	305	68	22	165	M16x36	100	+ 0.50 0	5	330	785	158	0
0 - 0.5	15	+ 0.43 0	340	360	275	765	70	85	223	190	100	345	68	22	165	M16x36	100	+ 0.50 0	5	330	825	158	0

外形尺寸 Dimension drawings

IM B3 安装结构型式 IM B3 construction type

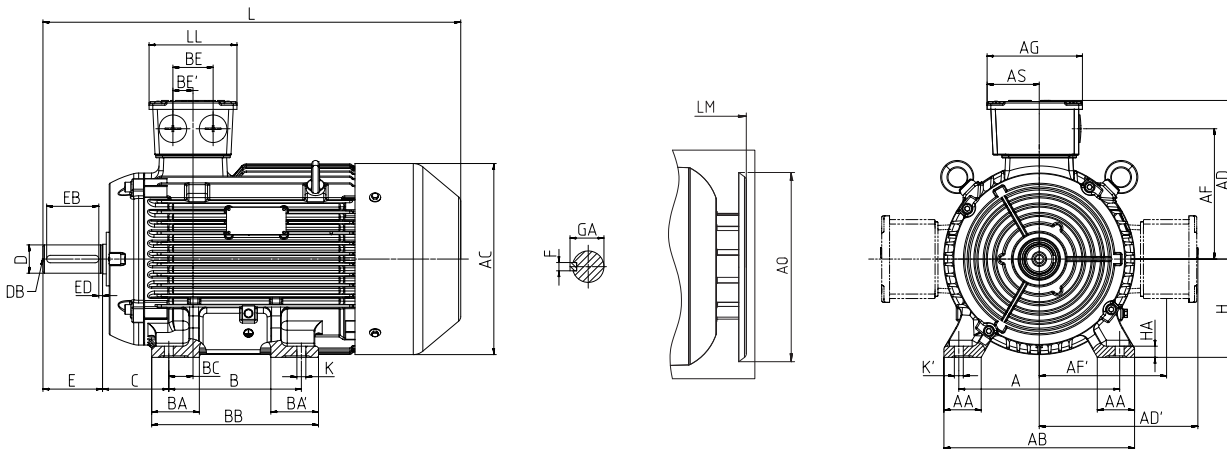

IM B35 安装结构型式 IM B35 construction type

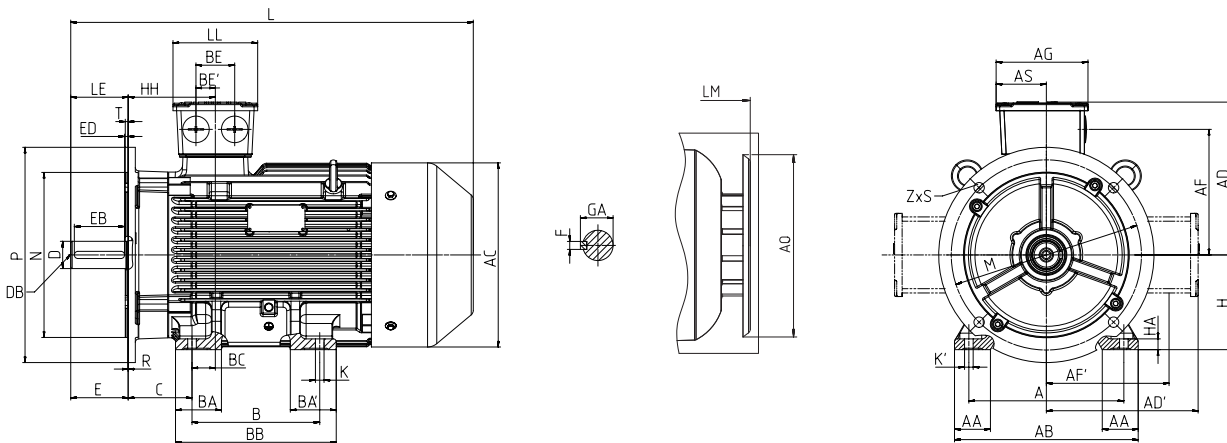

机座号 Frame size	订货号 MLFB 1MT0013	极数 Poles	尺寸及公差 /mm Dimension and toleranc											
			A	B	C		D		E		F		GA	H
					基本尺寸 Dimension	极限偏差 Tolerance	基本尺寸 Dimension	极限偏差 Tolerance	基本尺寸 Dimension	极限偏差 Tolerance	基本尺寸 Dimension	极限偏差 Tolerance		
200L	2AA4, 2AA5, 2AB4, 2AC4, 2AC5, 2AD5	2,4,6,8	318	305	133	± 3.0	55	+ 0.030 + 0.011	110	± 0.43	16	0 - 0.043	59	200
225S	2BB0, 2BD0	4,8	356	286	149	± 4.0	60	+ 0.030 + 0.011	140	± 0.5	18	0 - 0.043	64	225
225M	2BA2	2	356	311	149	± 4.0	55	+ 0.030 + 0.011	110	± 0.43	16	0 - 0.043	59	225
	2BB2, 2BC2, 2BD2	4,6,8	356	311	149	± 4.0	60	+ 0.030 + 0.011	140	± 0.5	18	0 - 0.043	64	225
250M	2CA2	2	406	349	168	± 4.0	60	+ 0.030 + 0.011	140	± 0.5	18	0 - 0.043	64	250
	2CB2, 2CC2, 2CD2	4,6,8	406	349	168	± 4.0	65	+ 0.030 + 0.011	140	± 0.5	18	0 - 0.043	69	250
280S	2DA0	2	457	368	190	± 4.0	65	+ 0.030 + 0.011	140	± 0.5	18	0 - 0.043	69	280
	2DB0, 2DC0, 2DD0	4,6,8	457	368	190	± 4.0	75	+ 0.030 + 0.011	140	± 0.5	20	0 - 0.052	79.5	280
280M	2DA2	2	457	419	190	± 4.0	65	+ 0.030 + 0.011	140	± 0.5	18	0 - 0.043	69	280
	2DB2, 2DC2, 2DD2	4,6,8	457	419	190	± 4.0	75	+ 0.030 + 0.011	140	± 0.5	20	0 - 0.052	79.5	280

¹⁾ 此尺寸为 80~280 顶出线、右出线及 80~160 左出线值，当 FS180~280 左出线时见表 2

The data for terminal box on top or right in FS80~280 and terminal box on left in FS80~160. When terminal box on left in FS180~280, please find the data in table 2.

IM B5 安装结构型式 IM B5 construction type



表 2 Table2 - 当接线盒在左边 (第 16 位 “6”) 时的底脚尺寸 Data for terminal box on left (16th digit 6)

机座号 Frame size	BA	BA'	BB
180	55	90	335
200	70	70	360
225	65	90	365
250	80	80	415
280	80	130	485

尺寸及公差 /mm Dimension and toleranc

H	K/K'		AB	AC	AD/AD'	L	AA	BA/BA' 1)	AF/AF'	AG	AS	BB ¹⁾	BE	HA	LL	DB	EB		ED	AQ	LM	HH	R
	极限偏差 Tolerance	基本尺寸 Dimension															极限偏差 Tolerance	基本尺寸 Dimension					
0 - 0.5	19	+ 0.52 0	380	400	310	795	75	85	250.0	245	110	375	85	25	220	M20x42	100	+ 0.50 0	5	370	875	203	0
0 - 0.5	19	+ 0.52 0	440	445	330	825	85	95	256	245	110	355	85	34	220	M20x42	125	+ 0.50 0	10	420	885	212	0
0 - 0.5	19	+ 0.52 0	440	445	330	850	85	95	256	245	110	380	85	34	220	M20x42	100	+ 0.50 0	5	420	910	212	0
0 - 0.5	19	+ 0.52 0	440	445	330	880	85	95	256	245	110	380	85	34	220	M20x42	125	+ 0.50 0	10	420	940	212	0
0 - 0.5	24	+ 0.52 0	490	495	380	920	95	105	296	295	130	425	84	40	250	M20x42	125	+ 0.50 0	10	460	1040	260	0
0 - 0.5	24	+ 0.52 0	490	495	380	920	95	105	296	295	130	425	84	40	250	M20x42	125	+ 0.50 0	10	460	1040	260	0
0 - 1.0	24	+ 0.52 0	545	545	420	980	105	138	353	295	130	460	84	40	250	M20x42	125	+ 0.50 0	10	520	1065	262	0
0 - 1.0	24	+ 0.52 0	545	545	420	980	105	138	353	295	130	460	84	40	250	M20x42	125	+ 0.50 0	10	520	1065	262	0
0 - 1.0	24	+ 0.52 0	545	545	420	1030	105	138	353	295	130	510	84	40	250	M20x42	125	+ 0.50 0	10	520	1115	262	0
0 - 1.0	24	+ 0.52 0	545	545	420	1030	105	138	353	295	130	510	84	40	250	M20x42	125	+ 0.50 0	10	520	1115	262	0

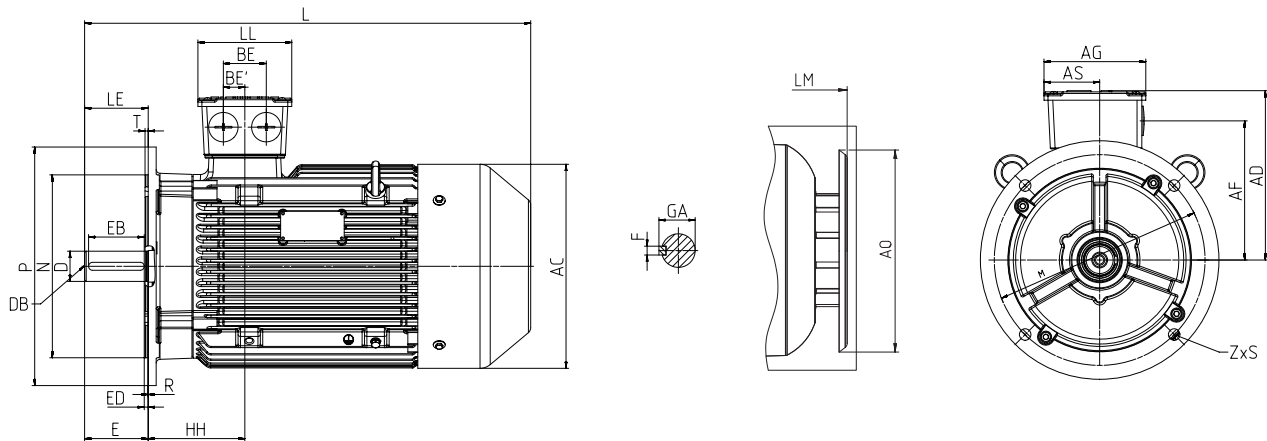
外形尺寸 Dimension drawings

IM B3 安装结构型式 IM B3 construction type

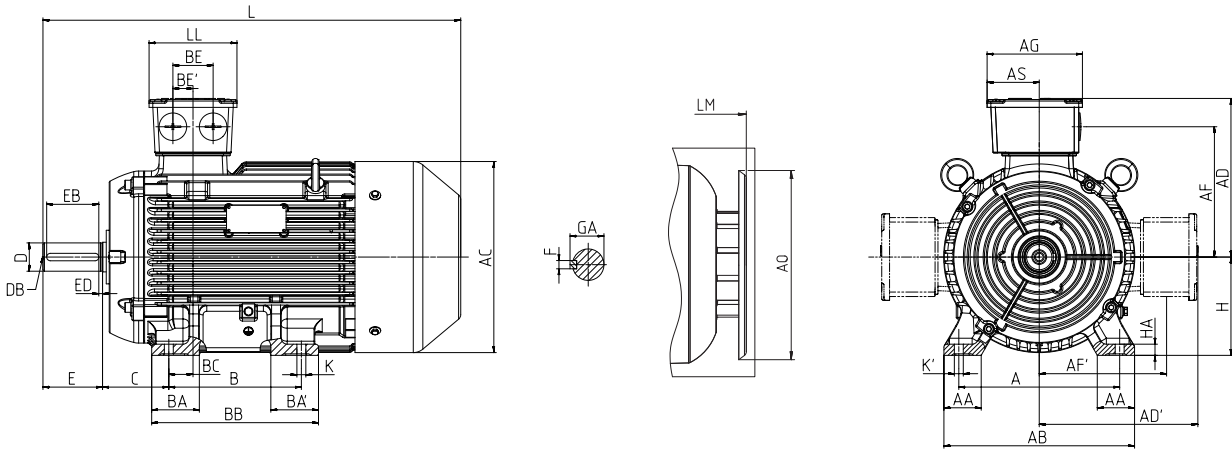

IM B35 安装结构型式 IM B35 construction type

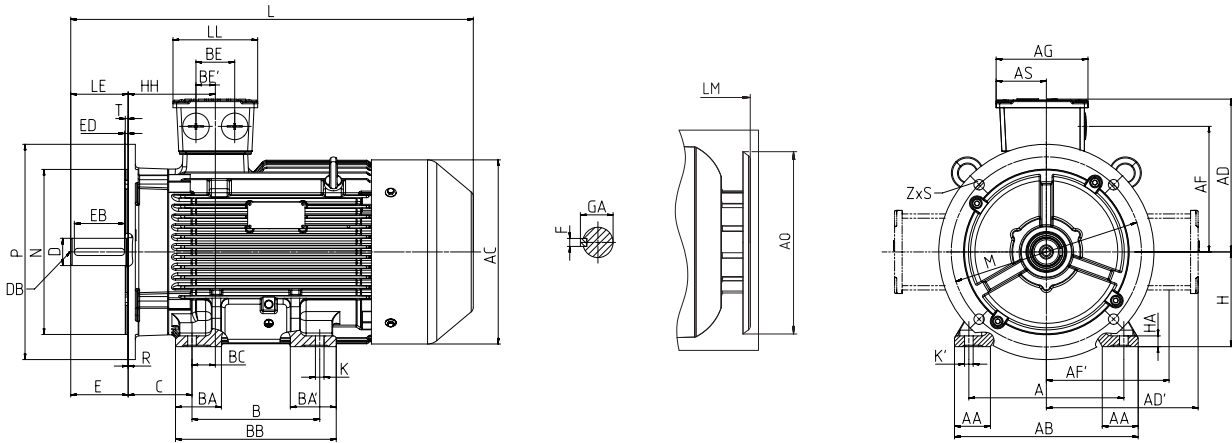

机座号 Frame size	订货号 MLFB 1MT0013	极数 Poles	尺寸及公差 /mm Dimension and toleranc												
			A	B	C		D		E		F		GA	H	
					基本尺寸 Dimension	极限偏差 Tolerance	基本尺寸 Dimension	极限偏差 Tolerance	基本尺寸 Dimension	极限偏差 Tolerance	基本尺寸 Dimension	极限偏差 Tolerance		基本尺寸 Dimension	
315S	3AA0	2	508	406	216		65		140		18	0 - 0.043	69	315	
	3AB0, 3AC0, 3AD0	4,6,8		406	216		80		170		22	0 - 0.052	85		
315M	3AA2	2	508	457	216		65	+ 0.030 + 0.011	140		18	0 - 0.043	69	315	
	3AB2, 3AC2, 3AD2	4,6,8				80			170		22	0 - 0.052	85		
315L	3AA5, 3AA6, 3AA7	2	508	508	216		65		140		18	0 - 0.043	69	315	
	3AB5, 3AB6, 3AB7, 3AC5, 3AC6, 3AD5, 3AD6	4,6,8				80		170		22		85			
355M	3BA2	2	610	560	254	± 4.0	75		140	0 -0.40	20		79.5	355	
	3BB2, 3BC2, 3BD2	4,6,8			95		+ 0.035 + 0.013	170			25		100		
	3BA3	2	610	560	254		75	+ 0.030 + 0.011	140			20		79.5	355
	3BB3, 3BC3, 3BD3	4,6,8			95		+ 0.035 + 0.013	170			25		100		
355L	3BC4	6	610	560	254		95	+ 0.013	170		25	0 - 0.052	100	355	
	3BA5	2	610	630	254	75	+ 0.030 + 0.011	140		20			79.5	355	
	3BB5, 3BC5, 3BD5	4,6,8			95	+ 0.035 + 0.013	170		25		100				
	3BA6	2	610	630	254	75	+ 0.035 + 0.013	140		20		79.5	355		
	3BB6, 3BC6, 3BD6	4,6,8			95	+ 0.035 + 0.013	170		25		100				

¹⁾ 此尺寸为 80~280 顶出线、右出线及 80~160 左出线值，当 FS180~280 左出线时见表 2

The data for terminal box on top or right in FS80~280 and terminal box on left in FS80~160. When terminal box on left in FS180~280, please find the data in table 2.

IM B5 安装结构型式 IM B5 construction type

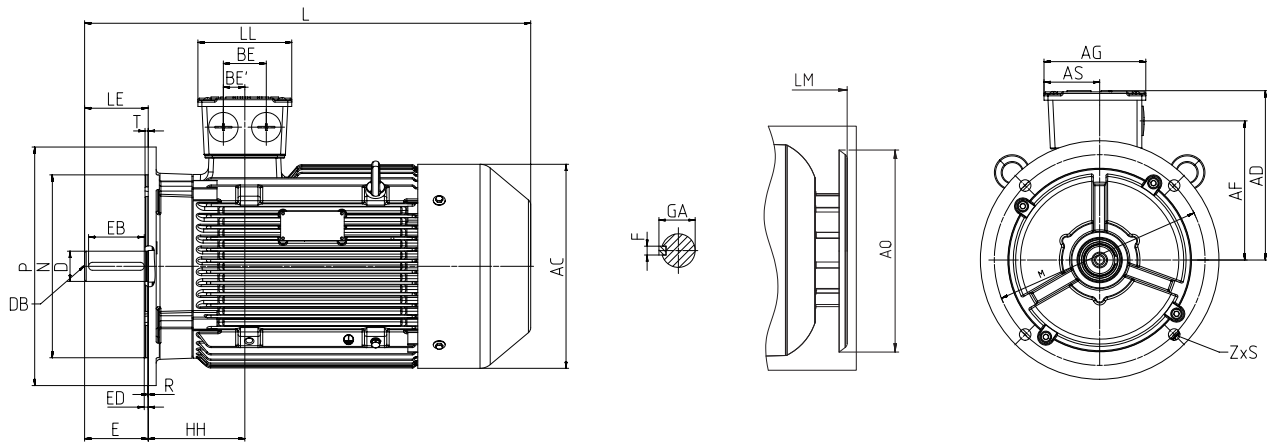

尺寸及公差 /mm Dimension and toleranc

H	K/K'		AB	AC	AD/ AD'	L	AA	BA/ BA' 1)	AF/ AF'	AG	AS	BB ¹⁾	BE	HA	LL	DB	EB		ED	AQ	LM	HH	R
	极限偏差 Tolerance	基本尺寸 Dimension															极限偏差 Tolerance	基本尺寸 Dimension					
0 - 1.0	28	+ 0.52 0	628	596	505	1205	120	\	410	380	160	577	110	125	310	M20	100	+ 0.5 0	8	580	1275	257	0
						1145						516					130						
			28	628	596	505	1205		120	410	380	160	577	110	45	310	M20	100	8	580	1275	257	0
							1235			130								5					
			28	628	596	505	1325		120	410	380	160	628	110	45	310	M20	100	8	580	1395	257	0
							1355			130								5					
	28	730	712	625	1370	120	514		514	181	696	125	53	362	M20	100	10	665	1440	281	0		
					1400		M24								130	5						665	1470
		28	730	712	625	1370	120		514	454	181	696	125	53	362	M20	100	10	665	1440	281	0	
						1400			M24							130	5						665
		28	730	712	625	1400	120		514	454	181	696	125	53	362	M24	130	5	665	1470	281	0	
						1490			M20							100	10						665
28	730	712	625	1490	120	514	454	181	750	125	53	362	M20	100	5	665	1590	281	0				
				1520		M24							130	5						665	1590	0	
28	730	712	625	1490	120	514	454	181	750	125	53	362	M20	100	10	665	1560	281	0				
				1520		M24							130	5						665	1590	0	

外形尺寸 Dimension drawings

IM B5 法兰尺寸 IM B5 flange dimensions

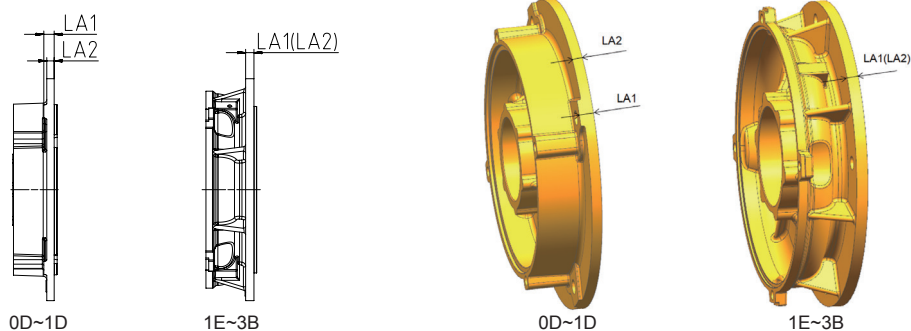

机座号 Frame size	IM B5/IM B35 法兰尺寸 IM B5/IM B35 flange dimensions								
	尺寸 Dimensions								
	LA1	LA2	LE	M	N	P	T	S	Z
80	10	7	40	165	130	200	3.5	12	4
90	10	7	50	165	130	200	3.5	12	4
100	11	8	60	215	180	250	4	14.5	4
112	11	8	60	215	180	250	4	14.5	4
132	14	10	80	265	230	300	4	14.5	4
160	14	10	110	300	250	350	5	18.5	4
180	14		110	300	250	350	5	18.5	4
200	15		110	350	300	400	5	18.5	4
225	16		110/140	400	350	450	5	18.5	8
250	18		140	500	450	550	5	18.5	8
280	18		140	500	450	550	5	18.5	8
315	22		140/170	600	550	660	24	6	8
355	25		140/170	740	680	800	24	6	8

机座号 Frame size	IM B14 法兰尺寸 IM B14 flange dimensions						
	尺寸 Dimensions						
	LE	M	N	P	T	S	Z
80	40	100	80	120	3	M6	4
90	50	115	95	140	3	M8	4
100	60	130	110	160	3.5	M8	4
112	60	130	110	160	3.5	M8	4
132	80	165	130	200	3.5	M10	4
160	110	215	180	250	4	M12	4

认证 Certificates



西门子电机（中国）有限公司

地址：江苏省仪征市汽车工业园众鑫路 99 号

电话：+86 514 85718108

传真：+86 514 85718083

邮编：211400

邮箱：beide-motor.ssml@siemens.com

网址：www.beide-motor.cn

SH902774-03182

西门子电机（中国）有限公司版权所有
如有改动 恕不事先通知。

Siemens Standard Motors Ltd.

Address: No.99,Zhongxin Road, Yizheng City, Jiangsu Province
211400,P.R.China

Tel: +86 514 85718108

Fax: +86 514 85718083

Post code: 211400

E-Mail: beide-motor.ssml@siemens.com

Web site: www.beide-motor.cn